

Igor Balać

Teaching Assistant

Milorad Milovančević

Associate Professor

University of Belgrade
Faculty of Mechanical Engineering

Petar Uskoković

Associate Professor

Radoslav Aleksić

Associate Professor

University of Belgrade
Faculty of Technology and Metallurgy

Stress Field Analysis around Optical Fiber Embedded in Composite Laminae under Transverse Loading

The influence of embedded optical fiber on stress state of transversally loaded composite laminae was analyzed in this paper. The optical fiber interaction with the host material (composite) has noticeable effect on the stress field of laminae. For considered load case, values of the component stresses in laminae with embedded optical fiber have values up to 40% higher than the nominal ones. For the observed loading scenario, optical fibers are acting as generators of evident but not significant stress, comparing to the stress concentrations that could arise, for instance, as a consequence of the shape geometry.

Keywords: composite laminae, optical fiber, plain strain, stress function .

1. INTRODUCTION

Prevention of serious damage of the composite structures may be achieved by monitoring the loading conditions and by inspecting the structural integrity using embedded optical fiber as sensors.

Interactions between the fiber optic sensors and the host materials, in the sense of correlation between optical signals and strains of the materials were subject of numerous studies [1-3]. Further, by using FE method, Barton et al. [4] investigated the effect of the thickness and Young's modulus of the fibre coating on the local stress distributions around an optical fibre sensor embedded in the 0° ply of a cross-ply GFRP laminate. Three positions of the sensor were analysed (adjacent to the 0/90 interface, in the middle of the 0° ply or at the laminate surface) with wide types of coatings (modulus from 0.045 to 10 GPa) and coating thickness (5-70 µm) were investigated.

Finite element techniques were used by Benchechou and Ferguson [5] in order to simulate the strain and stress concentrations in and around an optical fibre embedded in carbon fibre reinforced laminates. Analytical results produced show the location of high stresses and therefore the position of possible damage when specimens are subjected to tension and flexure. Also, mechanical fatigue tests are carried out on specimens with optical fibres embedded within different orientation plies, in order to see the effect of the fibres on the fatigue behavior of the specimens. Results are then compared with those found for a specimen without embedded optical fibre.

Dasgupta et al. [6] reported a linear elastic study in order to investigate the geometry of the resin rich region observed around fibre-optic sensors embedded in laminated 'adaptive' composites. Results of this analysis show the effect of laminate stacking sequence,

lamination pressure and optical fiber diameter on the geometry of the resin pocket; and are found to agree well with experimental observations. The problem of an arbitrarily varying axial strain field's transfer from material host to embedded fiber-optic sensor was studied by Duck and LeBlanc [7], which proposed a derivation by which the axial in-fiber strain field is predicted given an arbitrary, axially varying, strain field at some distance in the material host.

Hadžić et al. [8] studied the feasibility of embedding optical fibers in commonly used carbon-fiber composites. Based on tensile and compression tests on composites with embedded optical fibers, it was shown that significant deterioration on strength was observed beyond a certain optical fiber density level. This work was focused on the macroscopic effect of having optical fibres in composites from a structural integrity point of view.

The aim of this paper is analytic determination of the stress state in the vicinity of the embedded optical fiber. Obtained results were compared with the results of finite element modeling (FEM).

2. ANALYTICAL MODEL

Transversal loading of the laminae with the embedded optical fiber has been observed (Figure 1). Assuming that problem could be considered as plain strain case, it is obvious that the laminae strains in z directions are neglected. Thus, considered problem becomes 2D plain strain case.

The symmetry of this model allows the analysis to be carried out on one-fourth of the model. (Figure 2). For stress-strain analysis we adopted the model shown in Figure 2, with following assumptions: model consists of optical fiber (B) and composite host (A); both are homogeneous and linear elastic; optical fiber is isotropic and composite is transversally isotropic; optical fiber has circular cross section and is embedded parallel to the reinforcing fibers aligned to z axis; there is no relative motion between composite host and optical fiber; model is loaded with constant load - nominal stress (σ).

Received: April 2006, Accepted: May 2006.

Correspondence to: Igor Balać

Faculty of Mechanical Engineering,
Kraljice Marije 16, 11120 Belgrade 35, Serbia
E-mail: ibalac@mas.bg.ac.yu

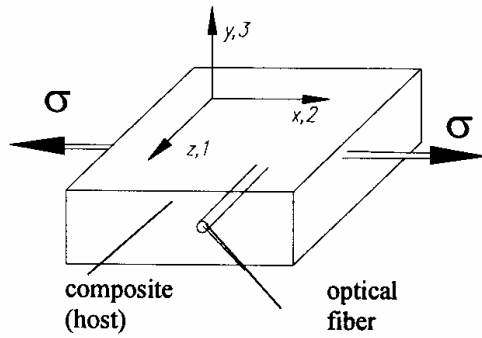

Figure 1. Model of composite with embedded optical fiber.

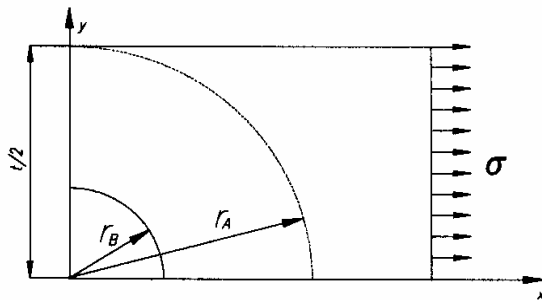

Figure 2. Adopted reduced model of composite (A) with embedded optical fiber (B).

Stress function (φ) in polar coordinates, for considered case, when $r \gg r_B$, is, [4]:

$$\begin{aligned} \varphi(r, \theta) &= \frac{\sigma}{2} r^2 \sin^2 \theta = \frac{\sigma}{2} \frac{r^2}{2} (1 - \cos 2\theta) = \\ &= \frac{\sigma}{4} r^2 - \frac{\sigma}{4} r^2 \cos 2\theta. \end{aligned} \quad (1)$$

On the other hand, for plain strain case, stress function, φ , must comply the following biharmonic equation, [4]:

$$\Delta \Delta \varphi(r, \theta) = 0 \quad (2)$$

where symbol Δ is Laplace's operator. The general form of stress function which fulfils equation (2) is given in [9] and it is called Airy's stress function.

Having in mind the symmetry of the model (relative to x and y axes), it can be concluded that in equation that represents the general form of Airy's stress function [9], all coefficients next to: θ , $\sin n\theta$ ($n=1,2,3,4,\dots$), and $\cos n\theta$ ($n=1,2,3,4,\dots$), should be equal to zero. Then Airy's stress function can be approximated as:

$$\begin{aligned} \varphi(r, \theta) &= A_0 + B_0 \ln r + C_0 r^2 + D_0 r^2 \ln r + \\ &+ \sum_{n=2,4,6,\dots}^{\infty} (A_n r^n + B_n r^{-n} + C_n r^{n+2} + D_n r^{2-n}) \cos n\theta. \end{aligned} \quad (3)$$

As unknown constant A_0 does not influence the stress state in composite, it can be assumed that $A_0=0$. Further, it can be proved that unknown constant $D_0=0$ [10]. If we hold only the first member of the sum in equation (3), neglecting higher order members, it follows:

$$\varphi_A(r, \theta) = A \ln r + B r^2 + \left(P r^2 + Q r^4 + \frac{R}{r^2} + S \right) \cos 2\theta. \quad (4)$$

As r rises, stresses have finite values and so $Q=0$, which yields:

$$\varphi_A(r, \theta) = A \ln r + B r^2 + \left(P r^2 + \frac{R}{r^2} + S \right) \cos 2\theta. \quad (5)$$

Composite component stresses, radial, tangential and shear stress are obtained as:

$$\begin{aligned} \sigma_r &= \frac{1}{r} \frac{\partial \varphi}{\partial r} + \frac{1}{r^2} \frac{\partial^2 \varphi}{\partial \theta^2} = \\ &= \frac{A}{r^2} + 2B - \left(2P + \frac{6R}{r^4} + \frac{4S}{r^2} \right) \cos 2\theta, \end{aligned} \quad (6)$$

$$\sigma_\theta = \frac{\partial^2 \varphi}{\partial r^2} = -\frac{A}{r^2} + 2B + \left(2P + \frac{6R}{r^4} \right) \cos 2\theta \quad (7)$$

$$\tau_{r\theta} = \frac{1}{r^2} \frac{\partial \varphi}{\partial \theta} - \frac{1}{r} \frac{\partial^2 \varphi}{\partial r \partial \theta} = \left(2P - \frac{6R}{r^4} - \frac{2S}{r^2} \right) \sin 2\theta. \quad (8)$$

Where unknown constants are: A, B, P, R, and S. Note if $r \gg r_B$ then from equations (1) and (6) follows:

$$\sigma_r = \frac{\sigma}{2} (1 + \cos 2\theta). \quad (9)$$

Similarly, stress function for optical fiber (B), considering that stresses inside the optical fiber have finite values, can be expressed as:

$$\varphi_B(r, \theta) = F r^2 + \left(K r^2 + M r^4 \right) \cos 2\theta, \quad (10)$$

resulting to the component stresses for optical fiber as:

$$\sigma_r = 2F - 2K \cos 2\theta, \quad (11)$$

$$\sigma_\theta = 2F + \left(2K + 12M r^2 \right) \cos 2\theta, \quad (12)$$

$$\tau_{r\theta} = \left(2K + 6M r^2 \right) \sin 2\theta, \quad (13)$$

where unknown constants are: F, K, M. The total number of unknown constants is 8 (A, B, P, R, S, F, K, M).

Coefficients that arise in stress equations are evaluated from the following boundary conditions:

1. $r = r_A$; $\sigma_{Ar} = \frac{\sigma}{2} (1 + \cos 2\theta)$;
2. $r = r_B$; $\sigma_{Ar} = \sigma_{Br}$;
3. $r = r_B$; $\tau_{Ar\theta} = \tau_{Br\theta}$;
4. $r = r_B$; $u_{Ar} = u_{Br}$;
5. $r = r_B$; $u_{A\theta} = u_{B\theta}$;

where radial and tangential displacements of composite (A) and optical fiber (B) are evaluated, after adequate integrations of Koshy's equations (in polar coordinates) [9], as follows:

$$u_{Ar} = \frac{1}{E_r} \left\{ -\frac{A}{r} (1 + \nu_{r\theta}) + \left(1 - \nu_{r\theta} - 2\nu_{zr}^2 \frac{E_r}{E_z} \right) 2Br - \left[(1 + \nu_{r\theta}) 2Pr - (1 + \nu_{r\theta}) \frac{2R}{r^3} - \left(1 - \nu_{zr}^2 \frac{E_r}{E_z} \right) \frac{4S}{r} \right] \cos 2\theta \right\}, \quad (15)$$

$$u_{Bz} = \frac{2}{E} \left[(1 - \nu - 2\nu^2) Fr - \left[(1 + \nu) Kr + \nu(1 + \nu) 2Mr^3 \right] \cos 2\theta \right], \quad (16)$$

$$u_{B\theta}(r, \theta) = \frac{2}{E} \left[(1 + \nu) Kr + (3 + \nu - 2\nu^2) Mr^3 \right] \sin 2\theta, \quad (17)$$

$$u_{A\theta}(r, \theta) = \frac{2}{E_r} \left[(1 + \nu_{r\theta}) \left(Pr + \frac{R}{r^3} \right) + \left(\nu_{r\theta} + 2\nu_{zr} \frac{E_r}{E_z} - 1 \right) \frac{S}{r} \right] \sin 2\theta. \quad (18)$$

Unknown coefficients are obtained from conditions presented as equation (14). For example, first condition (considering $r_A \gg r_B$) from equation (14) and (6), gives:

$$B = -P = \frac{\sigma}{4}. \quad (19)$$

Determination of the rest six constants is shown on the following numerical example. When unknown constants are determined, then component stresses, equations (6), (7), (8), (11), (12), (13), and displacements, equations (15),..., (18), are fully determined for every point of optical fiber and composite host.

3. NUMERICAL EXAMPLE

Optical fiber (glass) with diameter $125 \mu\text{m}$ ($r_B = 62.5 \mu\text{m}$) is embedded in 1 mm thick laminae, graphite fibers - epoxy resin, ($r_A = 500 \mu\text{m}$). Volume fraction of the graphite fibers is: $V_f = 0.7$. The material properties, used in this example, are adopted from the reference [11]:

- for laminae (host): $E_1 = E_z = 181 \text{ GPa}$,
 $E_r = E_\theta = 10.3 \text{ GPa}$, $\nu_{zr} = 0.28$, $\nu_{r\theta} = 0.3$;
- for glass (optical fiber): $E = 85 \text{ GPa}$, and $\nu = 0.2$.

It is assumed that nominal stress has value: $\sigma = 1 \text{ GPa}$.

After replacing these values in equations defining component stresses, (6), (7), (8), (11), (12), (13), and displacements, equations (15),..., (18), and solving equation system (14), unknown constants are obtained as:

$$B=0.25, A=609.281, S=-804.051, K=-0.349, P=-0.25, \\ R=1.593 \cdot 10^6, F=0.328, M=-7.463 \cdot 10^{-7}. \quad (20)$$

Validation of these analytically obtained values has been done by finite element method (FEM).

A comparison between the analytical and FEM results for radial and tangential normal stress, along x and y axes, is shown in Figure 3.

A very good agreement between the analytical and FEM results shown in figure 3 validates the general approach taken.

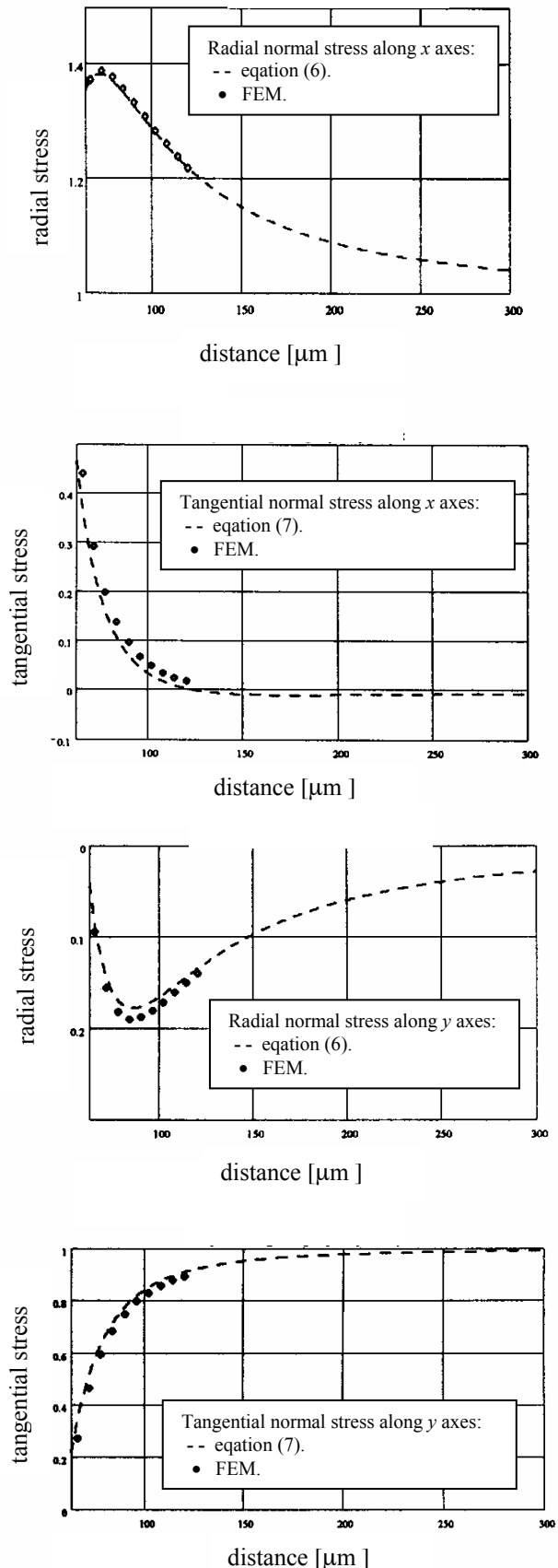

Figure 3. Distribution of radial and tangential normal stress in composite host.

4. CONCLUSION

Analytic determination of component stresses and displacements in the composite host, using Airy's stress function is relatively easy and acceptable.

Optical fiber embedded in composite laminae noticeably changes the stress state in its vicinity and with arising distance from the fiber, these values are approaching nominal ones.

In the case of transversal loading, peak values of the component stress in laminae with embedded optical fiber go above up to 40% than the nominal ones.

Peak values of component stresses are not observed on the composite host/optical fiber boundary surface, but on some distance of the fiber (Figure 3). For the observed loading scenario, optical fibers are not acting as generators of significant stress, comparing with the stress concentrations that could arise, for instance, as a consequence of the shape geometry.

The optical fibers could be successfully used as sensors in composite laminae and will not significantly compromise the strength of the composite host.

REFERENCES

- [1] Kollar, L.P., Van Steenkiste, R.J.: Calculation of the stresses and strains in embedded fiber optic sensors, *Journal of Composite Materials*, 32, pp. 1647-1679, 1998.
- [2] Van Steenkiste, R.J., Kollar, L.P.: Effect of the coating on the stresses and strains in an embedded fiber optic sensor, *Journal of Composite Materials*, 32, 1680-1711, 1998.
- [3] Melin, L.G., Levin, K., Nilsson, S., Palmer, S.J.P., Rae, P.: A study of the displacement field around embedded fibre optic sensors, *Composites Part A*, 30, pp. 1267-1275, 1999.
- [4] Barton, E.N., Ogin, S.L., Thorne, A.M., Reed, G.T.: Optimisation of the coating of a fibre optical sensor embedded in a cross-ply GFRP laminate, *Composites Part A*, 33, pp. 27-34, 2002.
- [5] Benckechou, B., Ferguson, N.S.: The effect of embedded optical fibres on the fatigue behaviour of

composite plates, *Composite Structures*, 41, pp. 113-120, 1998.

- [6] Dasgupta, A., Wan, Y., Sirkis, J.S.: Prediction of resin pocket geometry for stress analysis of optical fibers embedded in laminated composites, *Smart Materials and Structures*, 1, pp. 101-107, 1992.
- [7] Duck, G., LeBlanc, M.: Arbitrary strain transfer from a host to an embedded fiber-optic sensor, *Smart Materials and Structures*, 9, pp. 492-497, 2000.
- [8] Hadžić, R., John, S., Herszberg, I.: Structural integrity analysis of embedded optical fibres in composite structures, *Composite Structures*, 47, pp. 759-765, 1999.
- [9] Rašković D.: *Theory of elasticity*, Naučna knjiga, Beograd, 1985, (in Serbian).
- [10] Skudra, Bulvas: *Structural Theory of Reinforced Plastics*, Zinannie, Riga, 1977, (in Russian).
- [11] Kaw Autar K.: *Mechanics of Composite Materials*, CRC Press, New York, 1997.

АНАЛИЗА НАПОНСКОГ СТАЊА У ОКОЛИНИ ОПТИЧКОГ ВЛАКНА УГРАЂЕНОГ У КОМПОЗИТНУ ЛАМИНУ ПРИ ТРАНСФЕРЗАЛНОМ ОПТЕРЕЂЕЊУ

**Игор Балаћ, Милорад Милованчевић,
Петар Ускоковић, Радослав Алексић**

У овој раду анализиран је утицај уграђеног оптичког влакна на напонско стање трансферзално оптерећене композитне ламине. Уграђено оптичко влакно има приметан утицај на напонско поље композитне ламине. Вредности компонентних напона у ламини са уграђеним оптичким влакном имају и до 40% веће вредности од номиналних. За разматрани случај оптерећења оптичко влакно уграђено у композитну ламину јесте генератор приметних али не и значајних концентрација напона у поређењу са онима које, на пример, могу да се јаве услед геометрије облика.