

Application of Planetary Reduction Gear in Operation of the Two Rope Grab

Nenad A. Miloradović

Assistant
University of Kragujevac
Faculty of Mechanical Engineering,
Kragujevac

Blaža Ž. Stojanović

Assistant
University of Kragujevac
Faculty of Mechanical Engineering,
Kragujevac

Dobrovoje M. Čatić

Associate Professor
University of Kragujevac
Faculty of Mechanical Engineering,
Kragujevac

The paper presents the principles of calculation and design of crane's trolley intended to work with a two-rope grab having drive elements for moving and hoisting. The trolley moves along the lower girdle of the bridge crane. Mechanism for grab hoisting with two electric motors connected by a planetary reduction gear is considered. The role of the planetary reduction gear in selected solution for load hoisting drive is specially emphasized and calculation of main parameters of this gear is given. Operation principles of the grab's elements is presented and foundations of dynamic analysis during grab's operation are set.

Keywords: grab, clamshell, planetary reduction gear.

1. INTRODUCTION

The grabs are basic auxiliary devices of cranes that convey large amounts of bulk materials. There are different design solutions, according to the way they operate [1,2].

According to the given project task, a grab hoisting mechanism with two ropes and two electric motors coupled by the planetary reduction gear is adopted. The advantages of this mechanism are multiple:

- control of the mechanism is simple and synoptic and possibility of false engagement of the mechanism is practically excluded,
- possibility to close or open the grab in full speed of lowering, without previous stopping,
- smaller dimensions and smaller mass with respect to a mechanism with two independent electric motors and
- avoidance of overload of grab carrying ropes.

2. CALCULATION OF THE LOAD HOISTING MECHANISM

Electric motor, EM1, sets a grab holding drum, D1, in motion using the gear wheels 5-6 and 1-2, and the grab closing drum, D2, using the toothed gear 7, toothed gear outer rim, B, toothed gear inner rim, B, planetary toothed gear, C, carrier of the planetary toothed gear, N, with firmly connected toothed gear 3 and the toothed gear 4, Figs. 1 and 2. Opening and closing of the grab is performed only with electric motor EM2 (EM1 rests, brake is locked). Electric motor, EM2, drives the grab closing drum, D2, using the toothed gear A, planetary toothed gear C, carrier N and gear wheel 3-4. Satellite C rolls along the toothed gear inner rim B which stands still.

The ropes for closing the grab receive full load in the phase of grab closing and partial hoisting of the full grab. Grab holding ropes are fully loaded at a single

moment - only during opening of the full grab, while, afterwards, only the empty grab loads them. During grab hoisting, it is assumed that the ropes are loaded with 75 % of total load. The forces in the ropes and the tearing forces are calculated, and the standard steel ropes for load hoisting are selected based on weights of the load, the grab and the crane trolley.

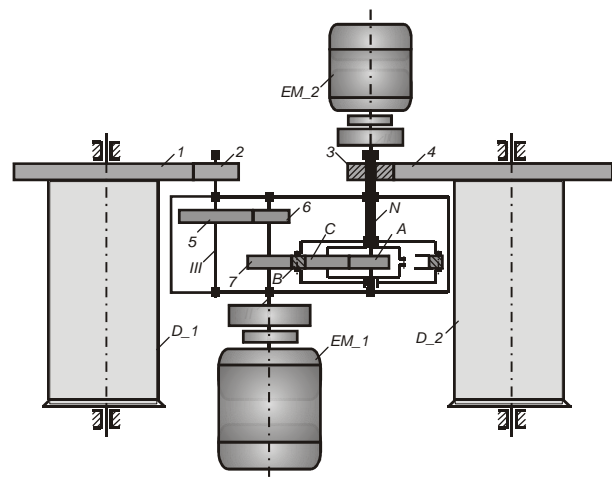

Figure 1. Layout of the load hoisting mechanism of the grab with two electric motors coupled by planetary reduction gear

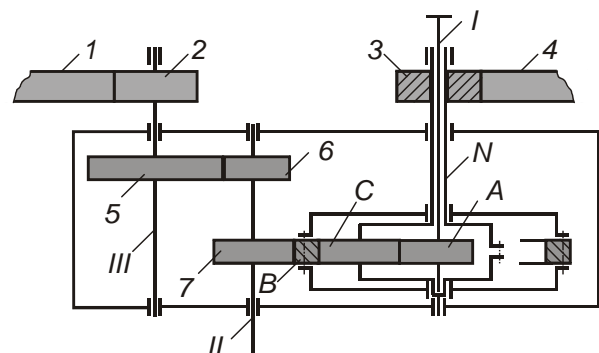

Figure 2. Layout of the planetary reduction gear

Dimensioning of the grab closing drum and the grab holding drum is performed and the electric motor, clutch and brake are selected.

Received: July 2009, Accepted: September 2009

Correspondence to: Nenad Miloradović, M.Sc.

Faculty of Mechanical Engineering,
Sestre Janjić 6, 34000 Kragujevac, Serbia
E-mail: mnenad@kg.ac.rs

2.1 Calculation of the planetary reduction gear

The planetary reduction gear is used for transfer of electric motors' power [3]. By application of the planetary reduction gear in design of grab's hoisting mechanism, the overload of the hoisting rope or insufficient closure of grab's clamshell are prevented. A complicated commanding with friction clutches and brakes during load manipulation is also avoided.

The compactness of design, large gear ratio, high efficiency ratio and demanded kinematical precision are achieved by using the planetary reduction gear, considering its role in the load hoisting mechanisms. At the same time, the distribution of the drive gear power into several simultaneously coupled toothed gears is possible, with the achievement of demanded reliability in different exploitation conditions [4]. The possibility to fill the space between central gears with a larger number of satellites enables good utilization of the inner space. Also, the application of a larger number of satellites enables the simultaneous load transfer with a larger number of teeth, which leads to load reduction and selection of smaller modules. Due to these features, the adopted planetary reduction gear is up to three times lighter than classic reduction gears of the same power and the same transmission ratio.

It is obvious that in planetary reduction gears the number of elements that may be used as leading or as driven elements is greater than in classical non-planetary mechanisms. Thus, considerable freedom is given to designers for final configuring of the construction.

The determination of positions of reduction gear members and speed of rotation of reduction gear elements and calculation of gear ratios, speeds and accelerations of individual gear elements are conducted within the kinematical analysis. The calculation of the planetary reduction gear consists from calculations of all toothed gears, shafts and satellite carriers. The synthesis of the reduction gear is achieved based on the known characteristics of motor, power, motor and drum speed, with the application of the general equation of motion of the planetary gears:

$$n_A - n_n = (-1)^m i_0 (n_B - n_n). \quad (1)$$

The following design demands should be met in order to achieve proper operation and free mounting: condition of coaxiality, condition of mounting and condition of vicinity [3,4].

The condition of coaxiality enables the equality of all center distance sin coupled gear couples. It may be written in the form of the following equality:

$$a_{A-C} = a_{B-C}, \quad (2)$$

or, finally, through the number of gear teeth:

$$Z_A + Z_C = Z_B - Z_C. \quad (3)$$

The condition of vicinity enables the necessary clearance between addendum circles of the adjacent satellites.

$$2 \cdot a_{A-C} \cdot \sin \frac{\pi}{n_w} \geq f + d_{aC}. \quad (4)$$

The increase of the number of planet gears, which may be positioned in one gear plane, is limited by clearance, which must be ensured between the addendum circles [5]. The constraint regarding the distribution of planet gears in one plane can be expressed in the form of the following inequality:

$$f(n_w, Z_A, i) = \sqrt{\frac{Z_A - 2.5}{Z_A \cdot i}} - \sin\left(\frac{\pi}{4} - \frac{\pi}{2 \cdot n_w}\right) \geq 0. \quad (5)$$

The total gear ratio for a basic type of mechanical gear is:

$$i = \frac{n_A}{n_N} = \left(1 + \frac{Z_B}{Z_A}\right). \quad (6)$$

The condition of coupling between the satellites and central gears is:

$$\frac{Z_A + Z_B}{n_w} = C. \quad (7)$$

It is necessary for the value of C to be an integer, which is satisfied.

The selection of the number of teeth on a central toothed gear, A, is conducted according to the recommendations [3]. The value of 25 is adopted, with which considerable advantages are gained: smaller surface pressure on teeth sides, higher root strength, smaller modules, smaller offsets during manufacture, smaller dynamic forces and smaller wear.

The power is transmitted through several parallel branches at the same time. The number of branches is equal to the number of single satellites in the planetary reduction gear, and this makes it possible to decrease foot load and to reduce at the same time the overall dimension of the gearing.

The resulting values of forces and moments at characteristic points are calculated respecting the conditions of mounting, coaxiality and vicinity, in order to dimension a shaft.

The analysis of forces during calculation of the planetary gear carrier is given in Figure 3.

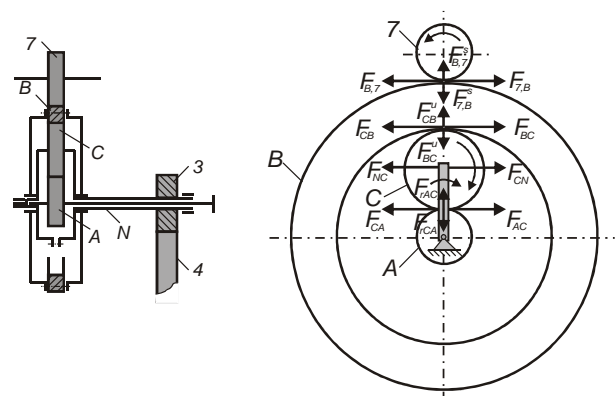

Figure 3. Layout of the planetary toothed gear carrier and the forces acting on the toothed gears

Taking into account the design demands and recommendations from the literature, the values presented in Table 1 are obtained.

By applying the planetary reduction gear, a very simple control over the load hoisting mechanism is

Table 1. Part of the values obtained during calculation of reduction gear and toothed gears of both drums

No.	Lable	Dimens.	Toothed gears								
			A	Bu	Bs	C	5	6	7	1(4)	2(3)
1.	Z	-	25	81	102	25	98	25	31	194	31
2.	<i>m</i>	mm	5	5	5	5	5	5	5	5	5
3.	<i>d</i>	mm	125	405	510	140	490	125	155	970	155
4.	<i>d_f</i>	mm	113	417	498	128	478	113	143	958	143
5.	<i>d_a</i>	mm	137	393	522	152	502	137	167	980	165
6.	<i>b</i>	mm	125	125	125	125	125	125	125	155	155
7.	<i>Z_w</i>	-	3	10	12	4	11	3	4	22	4
8.	<i>W</i>	mm	38.63	145.82	176.8	53.59	161.76	53.8	53.8	330.77	53.8
9.	<i>t</i>	mm	15.7	15.7	15.7	15.7	15.7	15.7	15.7	15.7	15.7
10.	<i>s</i>	mm	7.85	7.85	7.85	7.85	7.85	7.85	7.85	7.85	7.85
11.	<i>e</i>	mm	7.85	7.85	7.85	7.85	7.85	7.85	7.85	7.85	7.85
12.	material	-	C60	C45	C45	37MnSi5	C45	C45	C45	C45	C60
13.	σ_D	N/mm ²	285	255	255	340	255	255	255	255	285
14.	<i>M_o</i>	Nm	630.1	630.1	620.5	630.1	620.5	620.5	620.5	2432.5	2432.5
15.	<i>M_{oz}</i>	Nm	1235	1235	1216.2	1235	1048.7	1048.7	1048.7	3794.8	3794.8
16.	<i>F_{oz}</i>	kN	19.76	19.76	15.69	19.76	16.77	16.77	15.69	49.37	49.37
17.	σ_1	N/mm ²	8.28	1.43	1.12	7.41	1.19	4.67	3.66	0.84	2.18
18.	σ_H	N/mm ²	32.4	3.24	2.25	32.4	2.25	6.3	6.21	1.705	4.59
19.	<i>S_H</i>	-	3.9	2.27	2.02	4.37	1.9	1.35	1.72	2.04	2.1
20.	σ	N/mm ²	72.94	60.99	47.32	72.02	60.59	63.54	57.19	112.93	139.17
21.	<i>S_F</i>	-	3.91	4.18	5.31	4.72	4.28	4.01	4.45	2.26	2.143

achieved. Turning on the electric motor EM1 means the hoisting or lowering of the grab without changing its condition. With the corresponding selection of transmission, both drums rotate with the same peripheral speed. The grab is then hoisting or lowering, with no relative motion between the ropes. Turning on the EM2 means the opening or closing of the clamshells. By adjustment of the intensity of brake forces on brakes, the desired loading of the grab ropes for closing and holding may be achieved.

2.2 Grab trolley's frame and travel mechanism

The hoisting mechanism and the trolley travel mechanism are mounted on a grab frame made of girders having box shaped cross-sections, Fig. 4.

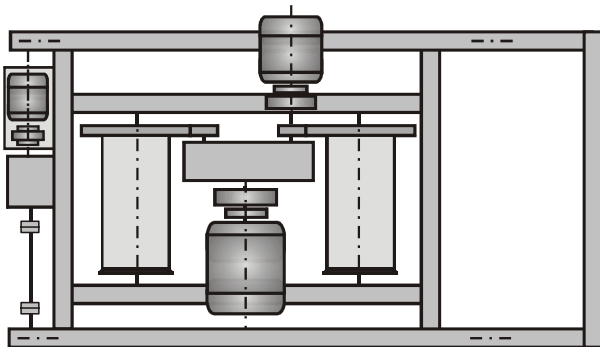

Figure 4. Layout of the trolley frame with the load hoisting mechanism

Since the trolley frame is a multiple statically indefinite system, it is hard to conduct an accurate calculation of dimensions of its side and cross girders.

The forces originating from the load, transfer mechanisms struts, motor, brakes, mechanism weights and frame carriers' own weights act on the carrying frame of the trolley. The calculation is done in such a way that the frame is dismantled to constituent girders that now represent simple beams with two struts, loaded with forces and related to other beams contacting them.

The operation of this grab demands design of trolley with two drums. Both drums may operate together or independently from each other.

The grab holding drum speed is $n_1 = 39.8 \text{ min}^{-1}$, while the grab closing drum speed is $n_2 = 36.19 \text{ min}^{-1}$. Speed reduction is conducted with planetary reduction gear that couples the drive motors of the load hoisting mechanism.

The drum axles are fixed and rest on a 10 mm sheet metals. Toothed gear for drum drive is bolted to the drum.

The grab stopping at specific height, after a period of hoisting or lowering, is achieved with brakes. Both motors have installed shoe brakes that achieve the braking with springs and unlocking with electric-hydraulic lift.

An electric motor having 3.53 kW of power is adopted for trolley drive, according to the calculations. Trolley's drive wheels are connected to electric motor via vertical reduction gear with the speed ratio of $i = 14$. The same brake type is used for stopping the trolley as for the hoisting mechanism. The drive wheels are connected to the drive axle by sprockets.

Control over the hoisting mechanism and the travel mechanism is conducted from the cabin situated on the trolley.

3. DYNAMIC ANALYSIS

The grab operation principles are presented in Figure 5.

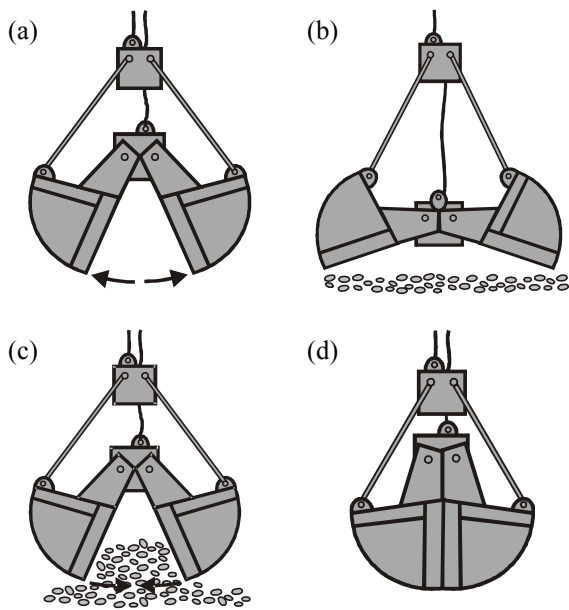

Figure 5. Operation principles of the two rope grabs

The opening of the grab is achieved by locking the hoisting drum, while the grab's full weight rests on the carrying rope, and the opening drum turns in the lowering direction, Fig. 5a.

In Figure 5b, a view of the grab with opened clamshell buckets during lowering is presented. Both drums turn in the lowering direction. The grab hangs on the carrying rope, while the closing rope is a bit relaxed. The grab lowering is conducted when it rests on the material to be lifted. After the grab is lowered, a period of closing and material gripping begins, Fig. 5c.

The closing drum turns in the direction opposite to the direction of grab lowering, while the other drum rests. At the moment when the grab clamshells come in contact, a period of hoisting the full grab begins. Both drums turn in the same direction then. The load is distributed between both ropes which wind onto the drums with the same speed.

In order to achieve the necessary force for clamshell closing in the period of closing, the rope force increases with the pulley situated in the upper and lower traverse. The pulley's speed ratio is $i = 3 - 6$.

According to the calculations and based on the crane trolley carrying capacity and hoisting speed, the following electric motors for driving the hoisting mechanism are adopted:

- grab holding motor with 79.4 kW of power and
- grab closing motor with 32.35 kW of power.

The optimal geometry of the grab's clamshell may be determined based on the analysis of forces.

The upper and lower sheave blocks, connecting arms and grab clamshells are observed during the analysis. Due to their small mass and way of travel, the arms are considered as constituent parts of the upper sheave block [1,6]. Considering that the device (structure) is symmetrical around the vertical axis, it is sufficient to set the equations of motion for one half of the clamshell bucket.

The following stands for the upper carrying sheave block, based on the balance of forces:

$$m_1 \ddot{y}_1 = F_r(i-1) - F_a \cos \alpha + W \quad (8)$$

The following is valid for the movement of the lower sheave block of the grab:

$$m_2 \ddot{y}_2 = -F_r i + F_a \cos \alpha + W - m_b \ddot{y}_b + m_b \cdot b g \cos(\varphi + \beta) \varphi^2 + F_{cv} + F_{ev} \quad (9)$$

The equations of rotation of buckets about the support b, Fig. 6, are:

$$I_b \ddot{\varphi} = m_b y_b \cdot b g \cdot \sin(\varphi + \beta) - W - M_e + F_a \sin \alpha \cdot b c \cos(\varphi + \theta) - F_a \cos \alpha \cdot b c \sin(\varphi + \theta) + F_{ch} \cdot a b \cos \varphi - F_{cv} \cdot a b \sin \varphi \quad (10)$$

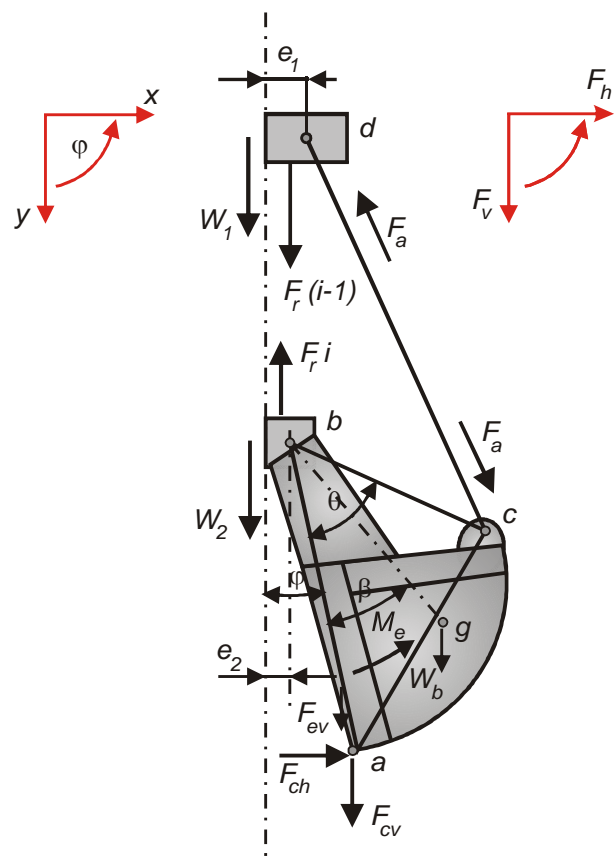

Figure 6. Analysis of forces

The initial system of nonlinear equations of motion is presented with a goal to set the dependence between motions of the upper sheave block, the lower sheave block and the bucket clamshell. It has been adopted that their motions depend on the angle of rotation of the bucket.

4. CONCLUSIONS

By numerical solving of the system of equations, the force that loads the carrying structure during grab's operation, the mechanism for load hoisting and the elements of the planetary reducing gear may be found.

The advantages of the planetary gears are: high speed ratios, high efficiency ratios, possibility of application of toothed gears with smaller modules,

possibility of division of power to several driven shafts and compact construction.

REFERENCES

- [1] Lobov, N.A.: *Dynamics of Transport Cranes*, Masinstroenie, 1987, (in Russian).
- [2] Ostrić, D. and Tošić, S.: *Cranes*, Faculty of Mechanical Engineering, Belgrade, 2005, (in Serbian).
- [3] Tanasijević, S. and Vulić, A.: *Mechanical Transmissions*, Faculty of Mechanical Engineering, Kragujevac, 2006, (in Serbian).
- [4] Rosić, B.: *Planetary Transmissions – Inner Cylindrical Couples*, Faculty of Mechanical Engineering, Belgrade, 2003, (in Serbian).
- [5] Rosić, B.: Parameter investigation and multicriteria design optimisation of planetary gear train, *Mobility and Vehicle Mechanics*, Vol. 28, No. 3-4, pp. 77-87, 2002.
- [6] Miedema, S. A. and Vlasblom, W. J.: The closing process of clamshell dredges in water-saturated sand, in: *Proceedings of the Conference Dredging Days 2006 – Protection of the Coastline, Dredging Sustainable Development*, 01-03.11.2006, Tangiers, Morocco.

NOMENCLATURE

ab	distance between cutting edge and bucket bearing
bc	distance between bucket bearing and arm bearing
bg	distance between bucket bearing and centre of gravity
α	angle of arm with vertical
β	angle between cutting edge, bucket bearing and bucket centre of gravity
φ	closing (opening) angle of bucket with respect to vertical axis
θ	angle between cutting edge, bucket and arm bearings
y_1	vertical position of upper sheave block
y_2	vertical position of lower sheave block
y_b	vertical position of bucket centre of gravity
F_a	force in one arm
F_r	force in the closing rope
F_{cv}	vertical force on the cutting edge
F_{ev}	vertical force on the side edges

F_{ch}	horizontal force on the cutting edge
I_b	mass moment of inertia of bucket
M_e	moment of side edge forces around bucket bearing
Z	number of gear teeth
m	module of toothed gear
d	toothed gear reference diameter
d_f	toothed gear root diameter
d_a	toothed gear tip diameter
f	clearance between adjacent satellites
n_w	number of satellite gears in one gear plane
a_{A-C}	centre distance for a teeth couple A-C
i_o	kinematical gear ratio of mechanical gear
b	toothed gear width
Z_w	number of teeth spanned
W	measure across the teeth
t	pitch
s	gear tooth arc thickness across pitch circle
e	arc width of groove across pitch circle
σ_D	permanent dynamic strength of gear tooth root
M_o	torque at toothed gear's shaft
M_{oz}	real value of torque
F_{oz}	real value of tangential load
σ_H	real reduced surface pressure
S_H	safety factor for gear tooth face
σ	real stress in gear tooth root
S_F	safety factor for gear tooth root

ПРИМЕНА ПЛАНЕТАРНОГ РЕДУКТОРА ЗА РАД СА ГРАБИЛИЦОМ СА ДВА УЖЕТА

Ненад А. Милорадовић, Блажа Ж. Стојановић,
Добривоје М. Ћатић

Рад обухвата принципе прорачуна и конструкцију дизаличних колица за рад са грабилицом са два ужета са елементима погона кретања и дизања. Колица се крећу по доњем појасу претоварног моста. Разматран је механизам за дизање грабилице са два електромотора повезаних планетарним редуктором. За изабрано решење погона за дизање терета, посебно је истакнута улога планетарног редуктора и дат прорачун главних параметара овог преносника. Наведен је принцип рада елемената грабилице и постављене основе динамичке анализе при њеном раду.