

# Applied Research for Weight Reduction of an Industrial Trailer

*The goal of this paper is to reduce the weight of a trailer with the aim to decrease both the transportation cost for goods and also reduce air pollution. The trailer is composed by many different components; each of them is studied and elaborated in order to achieve the target stated above. This operation may be done changing both the geometry and the materials used to produce the components. The main components are: the structural frame (composed by I-beams, transversal beams, brackets and rear bumper), the axels and the wheels; the materials used are a classical structural steel, a high strength steel, an aluminium alloy and a composite material. The main rule used in this process is that the new component must have almost the same mechanical behaviour of the original (safety factor, stiffness, dynamical behaviour, etc.). Therefore, many different load conditions have been performed and some of these were acquired from the relevant standard. The final trailer shows that there are many choices to reduce the weight and in particular, if the trailer is made of aluminium alloy and composite material, the weight reduction is about 45 %, compared with the structural steel.*

**L. Solazzi**

Assistant Professor  
University of Brescia  
Faculty of Mechanical Engineering

**Keywords:** trailer, vehicle, high strength steel, aluminium alloy, composite materials, wheel.

## 1. INTRODUCTION

This work starts from the consideration that in Italy the transport of goods on the road is about 70 % of the total (16 % by ship, 9.6 % by train, 0.4 % by airplane, the rest by pipeline e.g. the fuel). The transport of goods on the road is the major cause of pollution and in particular for Pm10 particles, very dangerous for the health of people. With these considerations it is mandatory to perform and develop an industrial vehicle, as described in this article. This target can be achieved in two ways: the first by reducing the fuel consumption, the second by increasing the carrying load capacity. This last choice may be performed for example by reducing the tare of the vehicle. The goal of this work is to study a new industrial trailer in order to reduce the weight of the main components which composed it [1,2]. The main components, of which the trailer is made, are:

- structural frame;
- transversal beams to connect the longitudinal beam of the main frame;
- brackets for the connection of the caisson;
- special brackets;
- rear bumper;
- axels and wheels.

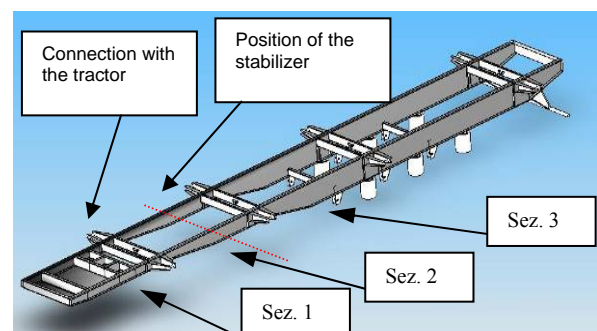
Each of these elements was studied with the target to reduce the weight and maintain almost the same values of the safety factors (about yield stress, fatigue phenomena and buckling phenomena), the stiffness, the

displacement, the dynamical behavior, etc., which are present in the original geometry. The main steps performed for each main element are:

- relief of the geometry of the component;
- study of the different load conditions acting on the component (by standards and by experimental tests);
- evaluation of the mechanical behavior of the components (safety factors, displacements, natural frequencies, etc.);
- choice of new different materials;
- development of a new geometry with the previous targets and comparison of the different solutions.

## 2. STRUCTURAL FRAME

The structural frame is essentially composed of two I-beams with different height, to withstand different bending stresses [1]. In order to evaluate completely the mechanical behaviour, different load cases were taken into account. Such of them are reported in the next figure.



**Figure 1. The trailer is full and in the first condition (A) the component is connected with the tractor; in the second condition (B) the component is supported by the stabilizers**

Received: January 2012, Accepted: February 2012.

Correspondence to: Dr. Eng. Luigi Solazzi  
Faculty of Mechanical Engineering,  
Dep. of Mechanical and Industrial Engineering,  
via Branze 38, 25123 Brescia, Italy  
E-mail: luigi.solazzi@unibs.it

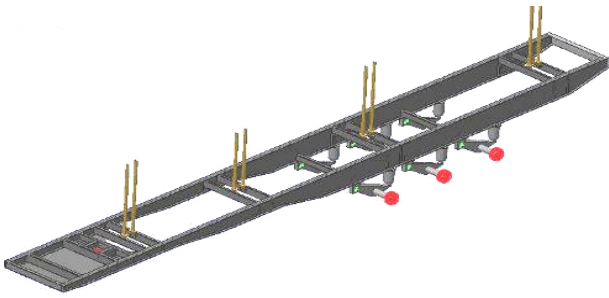


Figure 2. FEM model for the structural frame when the caisson is starting to turn laterally along the longitudinal axis

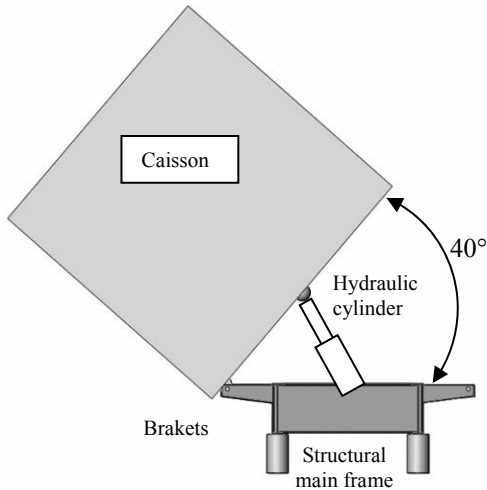


Figure 3. The caisson is at the maximum angle of rotation ( $40^\circ$ ). It is supposed that the load remaining inside the caisson is about the 50 % of the total load

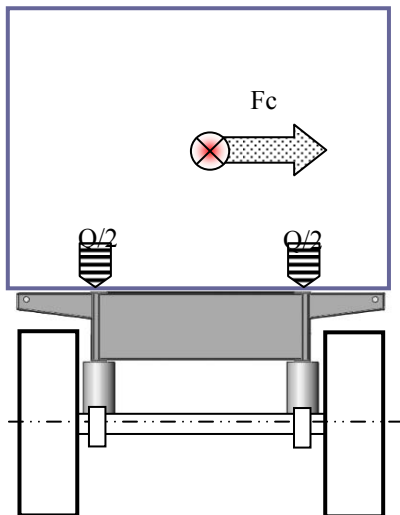


Figure 4. The trailer going into the street curves, subjected in this way to the centrifugal force applied to the centre of gravity of the load ( $V=65$  km/h,  $R=120$  m)

Under these different load conditions the original trailer was studied and then a different geometry of the trailer using different materials [3] was also developed.

With these material properties a new geometry of the structural frame was developed. The Table 3 shows, for each material, the different height of the I-beams for the components depending on the material; the position of the sections are reported in Figure 1.

Table 1. Different materials' properties concerning the material used for a new trailer

	Main mechanical properties			
	E [MPa]	Rs [MPa]	Rm [MPa]	A[%]
S355 JR UNI 10025-05	206000	490-630	510-680	16
Domex 690 _ SSAB	206000	690	750	15
Weldox 1300 _ SSAB	210000	1300	1400-1700	8
Al 6061 T6	70000	280	310	17

Table 2. Different height [mm] of I-beams for the structural main frame

	Materials			
	S355 JR	Domex 690	Weldox 1300	Al 6061
Section 1	240	180	90	180
Section 2	340	280	190	230
Section 3	460	400	250	350

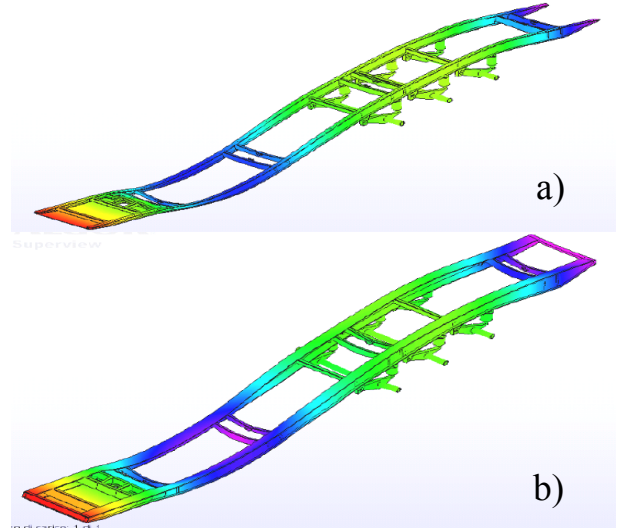


Figure 5. Results from FEM analyses for the structural frame under load condition defined in Figure 1 point A), with a) Weldox 1300 and b) Al 6061

Table 3. Different weights of the final structural frame

	S355 JR	Domex 690	Weldox 1300	Al 6061
Weight [kg]	1490	1350	1220	960
Variation [%]	0	-9.5	-18.1	-35.5

### 3. TRANSVERSAL BEAMS

These components join the two I-beams of the main structural frame and they are subjected to different load conditions. The most important load condition is induced by the hydraulic cylinder in the situation described in Figure 2 (start of lifting the caisson) [4-5]. In this load condition is present a dynamic load factor that increases the static load acting on the structures.

It is important to observe that the height of this component is fixed because it must be joined with the I-beam of the structural frame. The most critical

transversal beam is the one situated in the front position of the trailer because the I-beams present the minimum height, like transversal beam.

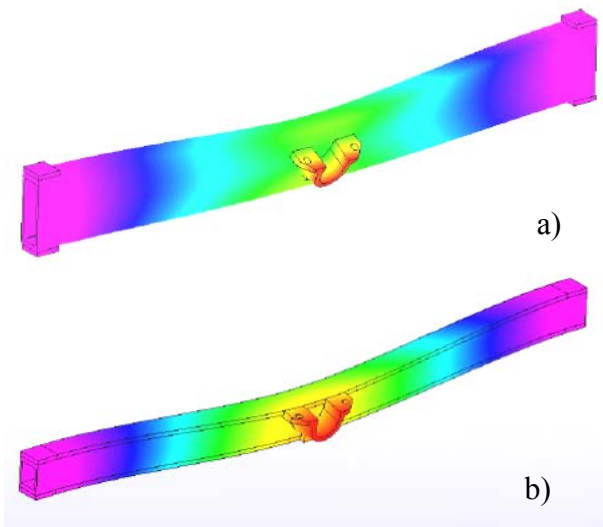


Figure 6. Results from FEM analyses of the transversal beams performed with a) Domex 690 and b) Weldox 1300. the maximum displacement is in correspondence of the hinge used to fix the hydraulic cylinder

#### 4. BRACKETS

As the previous components, the heights of these apparatus as are correlated with the height of the I-beams of the structural frame, and so for the brackets at the front of the trailer; it is necessary to increase the width of the components to contain the displacement of the component itself. When the caisson is at the maximum turning angle, there is a greater load on the component (load condition described in Figure 3).

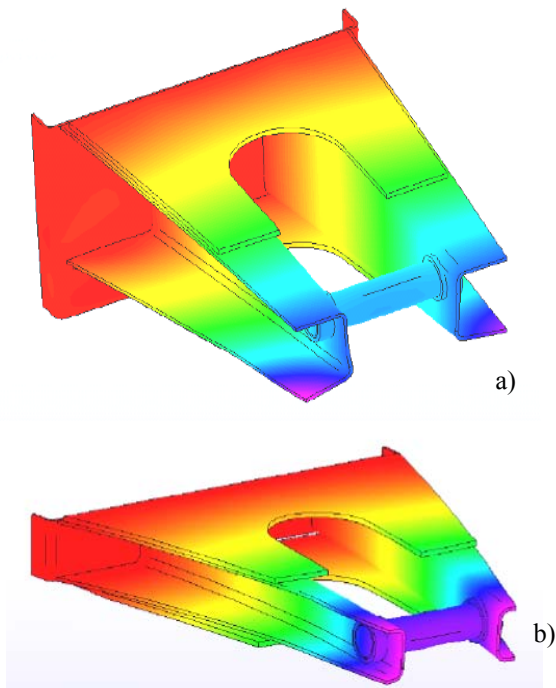


Figure 7. Results from FEM analysis for the brackets with a) Domex 690 and b) Weldox 1300, is important to observe the different height and the different width of the two solutions

#### 5. SPECIAL BRACKETS

It is obvious that on the vehicle there are many different elements, these components are, for example: the support for the gear box and for the wheel, for the air filter, etc. These components are analyzed with the aim to reduce the weight of the entire vehicle.

The Figure 8 represents, for example, the air filter with the relative support used for the fixage to the chassis of the vehicle. This item is made, in the original configuration, in a classical structural steel (S275 JR UNI EN 10025), while the study was conducted using a cast aluminum alloy and a cast zinc alloy. The load conditions considered for the numerical evaluation are different, and in general correlated to the vehicle direction and to the weight of the component that must be joined.

In summary, the external action is proportional to the inertia induced by the element weight in three basic directions (respect to the axis of vehicle): longitudinal, transversal and vertical. Another important consideration regards the dynamic behaviour and in particular the first natural frequencies which must be greater than a specific value in order to avoid that the roughness of the road can dynamically excite these elements.

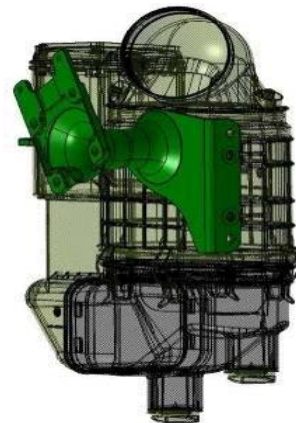


Figure 8. The air filter and the relative support (green)

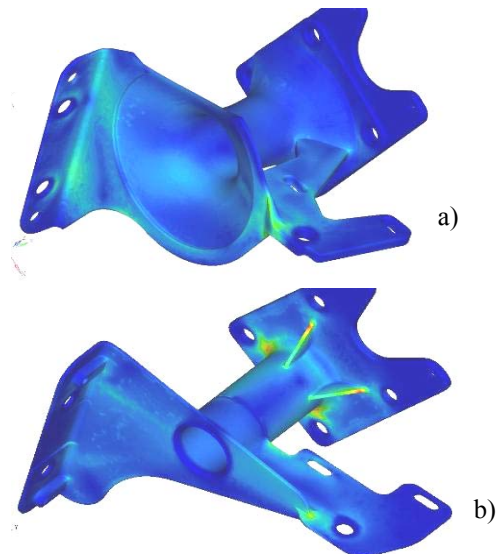


Figure 9. The results from FEM analyses, for two different architecture performed by using a different material a) aluminium alloy; b) zinc alloy

**Table 4. Materials properties**

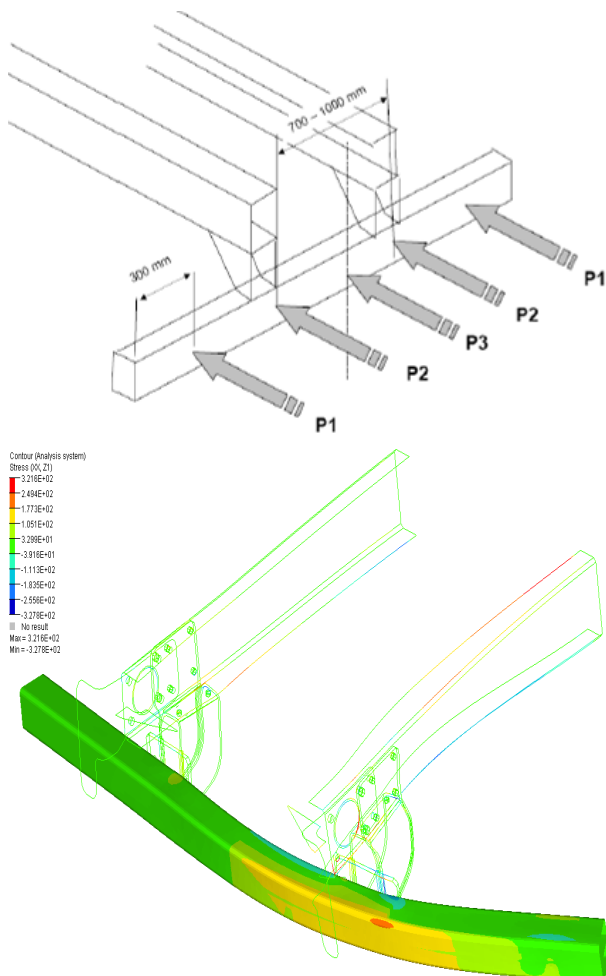
Material	S275 JR	Aluminum alloy G-AS12 C2 FZ	Zinc alloy
Yield Strength [MPa]	275	120	300
Weight [kg]	2.8	0.7	1.6
Weight Variation%	/	25	57

## 6. REAR BUMPER

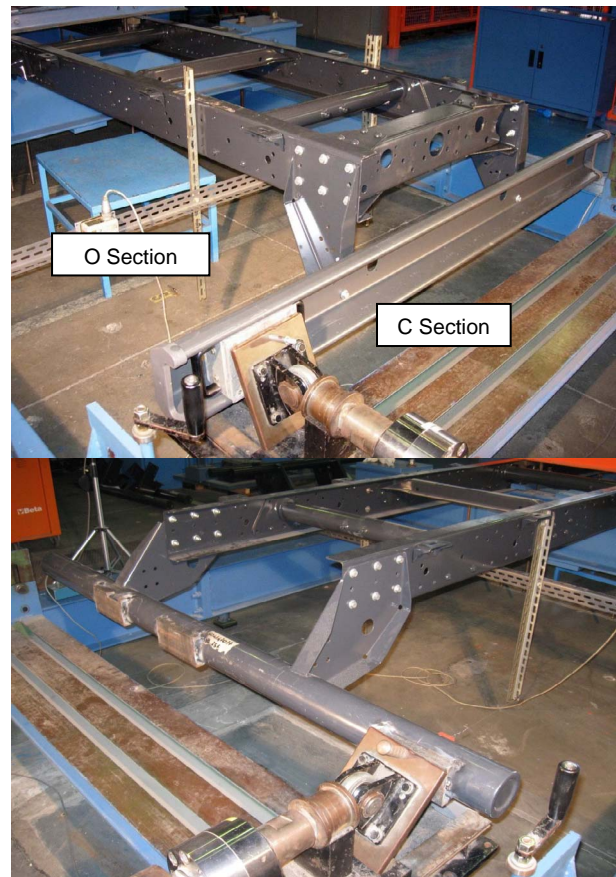
The Figure 11 shows the experimental tests performed on two different types of rear bar: the first at C section and the second at O section [6-10].

The different load conditions are defined by different standards and in particular by 70/221/CEE, which provides for significantly different loads than the previous standard 97/19 CEE. In synthesis, the new standard provides for the application of two loads, one near the end and another in the middle section of the bar, having a value equal to 25 % of the total mass of vehicle. The maximum horizontal force at the attachment point to the longitudinal bar of the vehicle is equal to 50% of the total mass of the vehicle.

The standard also prescribes rules that govern the maximum deflection of the bar in the respective load conditions. In the numerical elaboration, was applied a value of 50 kN in the first two load conditions, and a value of 100 kN in the last load condition.

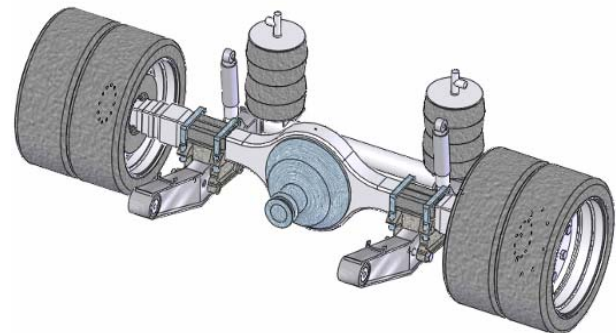


**Figure 10. Different load conditions for the new standard and numerical simulation**

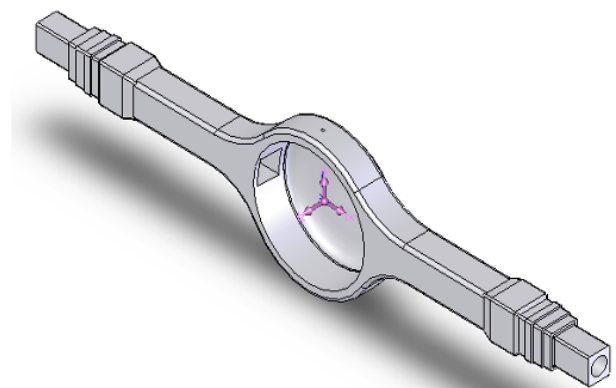


**Figure 11. Experimental tests on rear bumper with different section type**

## 7. AXELS



**Figure 12. Complete rear axle**

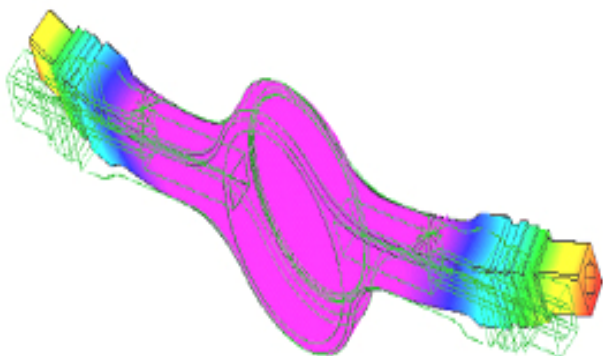


**Figure 13. Central component of the axle**

Figures 12 and 13 show the original geometry of the complete rear axel. This component is not on the trailer in exam because the trailer is without the traction, but the conclusion of this section may be extended to the rear axel of the trailer in exam.

The load conditions applied to the component are:

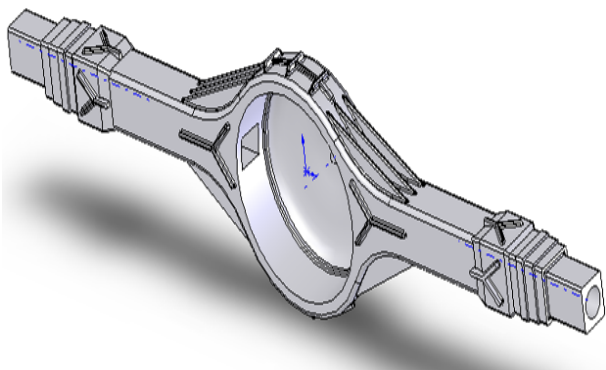
- vertical static load;
- vertical shock (+25 %);
- lateral load;
- torsional load (induced, for example, by the blocking of the wheel).



**Figure 14. Displacement for the central component of the axel in the last load condition**

The material choice for this component is a classical aluminium alloy (535.0 Al-7Mg,  $\sigma_R=275$  MPa,  $\sigma_y=140$  MPa A=13 %) made with the lost wax process.

The final geometry of the central component is reported in Figure15.



**Figure 15. Final geometry of the central component made of aluminium alloy**

The original weight of this component is about 116 kg, while in the final solution the weight is about 38 kg, with a reduction of about 60 %.

## 8. WHEELS

Another part that may be developed in order to reduce the weight is composed by the wheels of the vehicle. Now these components are made out of steel and in few cases it is made out of aluminum. In this work the wheel is proposed in composite material [11-13].

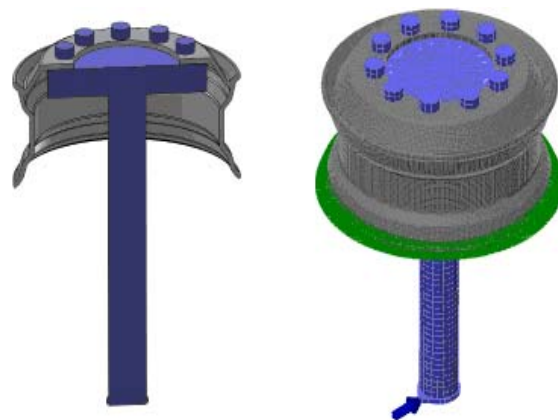
The first load condition applied on the numerical model is the classical load induced in the experimental test by a bending rotation machine. This choice respects the classical procedure used by firms that made these

components. The real stress state detectable in the component in the real load condition is quite different compared with the stress field induced by the experimental test with the rotation bending machine, but this test is easier to realize in comparison to other tests, like impact and contact fatigue test. The bending test provides a first evaluation of the correct design of the wheel and the other experimental tests will perform it subsequently.

The target of the design is to reduce the weight and to maintain the previous values of the safety coefficient, the flexibility or rigidity and the necessary space, close to the wheel, for other components like brake gripper (brake shoe).

The work starts with the classical component made of by steel; the size is 22.5 x 9, with an external diameter of 600 mm and a width of 200 mm. This wheel may be used for the truck and for the trailer.

The Figure 16 shows the original geometry and the numerical model for the FEM analyses. After an initial phase in which there were a series of numerical analyses with the aim of achieving convergence of the numerical solution, the next phase regards the evaluation of the maximum stress and displacement in the wheel. These quantities were also used to estimate the safety factor and the stiffness of the component for this specific load condition. Adopting the new material, the new phase was an iterative change of the geometry, trying to get at least the same mechanical performance with the dimensional constraints required for the accessories.



**Figure 16. Solid and Fem model for the bending test**

For the wheel, the aluminium alloy is a classical 6061 T6 (ISO AlMg1SiCu) while the composite materials used are two different types. The material for the skins is fibre glass (2 glass / Epoxy at 63 % in volume) while the material for the core is a foam honeycomb produced by the Nidacore company (NidaFoam Pet 150). The reason of this choice is essentially economic.

It is very important to underline that it is not possible to fix the wheel to the hub by bolts because the compression is too high for the material and so it is necessary to insert a steel sheet in the structure (Figure 17). The final weights for the different solution are: 40.5 kg with steel, 24 kg with aluminium and 9.8 kg with composite materials. With the composite material the weight reduction is equal to  $\approx -41\%$  respects to Al and  $\approx -76\%$  respects to steel.

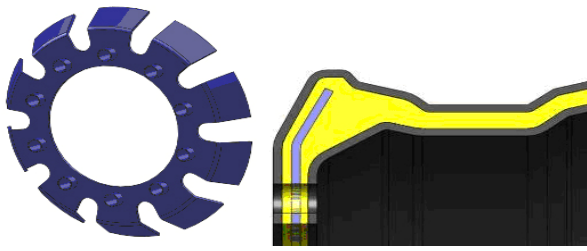


Figure 17. Solid model of wheel in composite material

## 9. CONCLUSION

This work wants to show a possible way to an important weight reduction of a trailer using different materials.

The final reduction depends on the type of the trailer: considering, for example, a vehicle composed of three axles and ten wheels having an initial weight of 4800 kg, is possible to obtain a weight of 2900 kg using an aluminum alloy for the structures and composite material for the wheels, with a reduction of about 45 %.

It is very important to underline that each component that composes the trailer and in general the machine can be studied in order to reduce the weight. For this purpose, it is very important for a designer to know the complete mechanical behavior of the materials involved in order to design a new component which is able to benefit from the properties of the new materials.

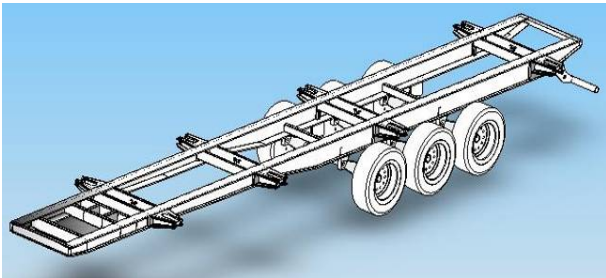


Figure 18. Example of the final trailer with the aluminium frame.

## REFERENCES

- [1] Fenton, J.: *Advances in Vehicle Design. Professional*, Engineering Publishing, 1999.
- [2] Happian, S.J.: *An Introduction to Modern Vehicle Design*, Butterworth-Heinemann, 2001.
- [3] Murray, G.T.: *Introduction to Engineering Materials, Behaviour, Properties, and Selection*, Marcel Dekker, 1993.
- [4] Donzella, G., Matteazzi, S. and Solazzi, L.: Experimental and numerical analysis of the body of a refuse collecting vehicle, *International Journal of Computer Applications in Technology*, Vol. 22, pp. 89-97, 2004.
- [5] Matteazzi, S. and Solazzi, L.: Influence of sequence of stress on fatigue damage, in: *Proceedings of the Ninth International Conference on Structural Safety and Reliability, Iccosar '05*, 19-23.06.2005, Rome, Italy

- [6] Solazzi, L.: On the dynamic effects induced by different laws of load application in lifting, *Brescia Ricerche*, No. 47, pp. 18-22, 2004, (in Italian).
- [7] Wheeler, A.J., and Ganji, A.R.: *Introduction to Engineering Experimentation*, Pearson Prentice Hall, 2003.
- [8] Dally, W.J. and Riley, W.F., *Experimental Stress Analysis*, McGraw Hill, 1991.
- [9] Dally, W.J., Riley, W.F., and McConnell, K.G.: *Instrumentation for Engineering Measurements, Second edition*, John Wiley and Sons, Inc., 1993.
- [10] Marsh, K.J.: *Full Scale Fatigue Testing of Components and Structures*, Butterworths, 1988.
- [11] Kaw, K.: *Mechanics of Composite Materials*, Boca Raton, CRC Press, 1997.
- [12] Solazzi L.: *Influence the design of composite material on the mechanical behavior of the cantilever – type spring*, Ninth International conference on Experimental techniques and design in composite materials, 30.09-02.10.2009, Vicenza, Italy.
- [13] Solazzi, L.: Wheel rims for industrial vehicles: comparative experimental analyses, *International Heavy Vehicle Systems*, Vol. 18, No. 2, 2011.

## ИСТРАЖИВАЊЕ СМАЊЕЊА СОПСТВЕНЕ МАСЕ ИНДУСТРИЈСКЕ ПРИКОЛИЦЕ

Луиђи Солаци

Циљ истраживања у овом раду је смањење тежине индустријске приколице у циљу смањивања транспортних трошкова превоза робе као и смањење загађења ваздуха. Приколица је састављена од много различитих компоненти, а свака од њих је анализирана и испитана. Смањење сопствене масе се може остварити променом како геометрије тако и материјала који се користе за производњу компоненти.

Главне компоненте су: конструкција рама (састављена од I носача, попречних греда, држача и задњих браника), осовине и точкови; коришћени материјали су класични конструкциони челици, челици високе чврстоће, легуре алуминијума и композитни материјали.

Основно правило коришћено у овом процесу јесте да нова компонента мора да има скоро исто механичко понашање као и оригинална (фактор сигурности, крутост, динамички понашање, итд). Из тог разлога више различитих случајева оптерећења су анализирана и нека од њих су проистекла из релевантних стандарда. Коначно решење приколице показује да постоји много могућности да се смањи њихова сопствена маса, нарочито ако је приколица је направљен од легуре алуминијума и композитних материјала, и тада је то смањење око 45 %, у поређењу са класичним решењима изведеним од конструкционих челика.