

Mathematical - Physical Model of Solving Inventive Problems

Dusan S. Rajic

Principal Research Fellow
University of Belgrade
Innovation Center of the Faculty of
Technology and Metallurgy

The spatial-temporal LT- contradiction matrix is an inventology tool that enables exact calculations of certain parameters in an engineering system through mathematical-physical modeling. It objectifies the decision-making process and creates the preconditions to finding an adequate resource (X-element) with a higher probability, and thus to reach a higher degree of ideality solution (HDIS) of an inventive problem as well. Any engineering system that generates an inventive problem can be described using the LT-contradiction matrix. By crossing the appropriate parameters in the LT- contradiction matrix, with the help of the differential geometry of the tensor, a qualitative-quantitative analysis and calculation of relevant degree all contradictions that exist in the inventive problem can be performed. After that, the path to finding the physical characteristics of the X-element in the mathematical-physical model is facilitated, i.e. finding a real resource that will enable a HDIS of the inventive problem in an engineering system.

Keywords: TRIZ, LT-contradiction matrix, inventology, mathematical-physical model.

1. INTRODUCTION

The theory of inventive problem solving (TRIZ, Russian abbreviation) and the space - time LT - table of physical quantities are two different dialectical tools used to solve inventive problems in engineering systems (ES) [1]. TRIZ is a heuristic methodology, created on the basis of the discovery of the law of evolution of ES in patent documentation [2]. The main disadvantage of TRIZ is reflected in the excessive influence of subjectivity in the decision-making process [3]. The LT-table is essentially a mathematical-physical system based on the axiom of equality of inertial and gravitational mass using the expression L^3T^{-2} , and includes natural laws represented by the general expression L^mT^n , where $|m + n| \leq 3$ for three-dimensional space [4, 5]. The Bartini system has two basic units of measurement, the length L and the time T. Dimensions of all other physical quantities are expressed in basic units with the corresponding exponent. The advantage of the Bartini system is that there are no exponents with fractional values. The rows of the matrix determine the dimension of the time T, and the columns of the matrix determine the dimension of the length L [4, 5]. This system can be correlated with the International System of Units of Measurement (SI) [6-8]. The main disadvantage of Bartini's LT-table of physical quantities is the vagueness when it comes to its possible practical application in solving inventive problems [1]. The authors tried to compensate for this vagueness in their works [9-12]. The focus of his research is on finding a connection between the Inventive Problem Solving Algorithm

(ARIZ, Russian abbreviation) as the most powerful tool of TRIZ and Bartini's LT-table of physical quantities. Only in the works [1, 3, 13-16] there is a correlation established between Altschuller's contradiction matrix as the most popular and most represented tool of TRIZ and Bartini's LT-table of physical quantities. By critically considering and upgrading these two tools, the LT-contradiction matrix was created as a new tool of inventology that offers solutions for 3210 different contradictions that may appear in inventive problems [1, 3, 13, 15, 16]. This is significantly more than in the case of the TRIZ contradiction matrix or in the case of the Bartini's LT-table. Common to all three mentioned tools is the fact that they start from the dialectical principle according to which contradictions are hidden in the basis of every problem, including the inventive one. They arise when one wants to improve one ES parameter, inevitably worsening the other, which is generically related to it. This is how technical contradictions (TC) arise. There are physical contradictions (PC) inside TC. They occur when two extremes of the same physical property (e.g., hot-cold, strong-weak, etc.) are simultaneously represented in one element of ES. By finding an adequate resource (the so-called X-element) inside or outside the ES, preconditions are created for removing contradictions, and thus a solution to the inventive problem as a whole is reached.

Since there are several TCs and PCs in one inventive problem, it is very important to choose the one that has the greatest impact on the occurrence of the problem. It is also necessary to choose the X-element based on its qualitative-quantitative analysis. This cannot be done without translating real ES into its abstract mathematical-physical model. The LT-contradiction matrix is an adequate mathematical-physical tool that allows to determine the most relevant contradiction in the inventive problem with exact precision using tensor calculus and calculate the X-element with the required

Received: May 2021, Accepted: June 2021

Correspondence to: Dr Dusan Rajic
Innovation Center of the Faculty of Technology and
Metallurgy, 4 Karnegijeva St., 11120 Belgrade, Serbia
E-mail: drajic@tmf.bg.ac.rs

doi:10.5937/fme2103726R

© Faculty of Mechanical Engineering, Belgrade. All rights reserved

FME Transactions (2021) 49, 726-733 726

physical properties whose introduction in the form of a real resource achieves a higher degree of ideality solution (HDS) of a problem in an ES.

2. TENSORIAL CALCULATION OF RELEVANT DEGREE OF CONTRADICTIONS

The LT-contradiction matrix meets all three criteria of scientificity. These are the criterion of measurability of all physical quantities that it encompasses, the criterion of their invariance regardless of the coordinate system in which the event takes place and the criterion of proportionality according to which everything changes in order to remain unchanged. This inventory tool includes 64 parameters presented in the form of the general expression $L^m T^n$ [1, 3, 13, 15, 16]. The LT-contradiction matrix has 7 fields of ES evolution that are defined by the value of the evolutionary gene $s_{m+n} = \pm(0,1,2,3)$. Each of the 64 parameters can be a parameter that is repaired (x), a parameter that breaks down (y) and a parameter that represents the required X-resource, i.e., the solution of TC in the form of expressions (xy) or (xy^{-1}), as well as the solution of PC in the form of the expression (x^2).

By crossing two different parameters x and y , TC is created, and by crossing the same parameter x with itself, PC is created.

When describing scalar quantities such as mass, temperature, density, etc., one datum is sufficient. Vector quantities such as force, velocity, acceleration, etc. are described in the selected coordinate system using three data (with 3 coordinate vectors). In doing so, knowing the coordinates of a vector in one system, the coordinates of the same vector in any other system can be determined. In addition to scalar and vector quantities, some physical phenomena such as inertia, deformation, stress, etc. require in their description also more complex vector tensors which are described in the coordinate system by index data. A scalar can be understood as a zero-order tensor (without an index), a vector as a first-order tensor (with a single index), and tensors are also observed in multidimensional spaces, and then the indices receive as many values as the space has dimensions. In Bartini's LT-table, tensors are used in a three-dimensional space. The physical quantities from the LT-contradiction matrix are translated into the rows of the matrix determined by the time dimension T , and the columns of the matrix represent the dimensions of length L . In the LT-contradiction matrix the parameter $L^0 T^0$ has the value $m = n = 0$. This value represents the radian or the rotation of the point, with no motion. Based on this fact, a coordinate system with zero values for m and n and with center 0 located in the cell $L^0 T^0$ is introduced.

If x denotes a parameter from the LT - matrix that is being repaired, and y denotes a parameter that automatically deteriorates, then we get:

$$x = \begin{bmatrix} L^m & 0 \\ 0 & T^m \end{bmatrix}, y = \begin{bmatrix} L^m & 0 \\ 0 & T^n \end{bmatrix}$$

TC shown as product xy takes the following form:

$$TC_{(x,-y)} = \frac{x}{y} = \begin{bmatrix} L^m & 0 \\ 0 & T^m \end{bmatrix} \times \begin{bmatrix} L^m & 0 \\ 0 & T^n \end{bmatrix}^{-1} = \begin{bmatrix} L^{m-m_2} & 0 \\ 0 & T^{m-n_2} \end{bmatrix} \quad (1)$$

The determinant $D_{(x,y)}$ of this matrix is represented as follows:

$$D_{(x,y)} = L^{m_1+m_2} \times T^{m_1+n_2} \quad (2)$$

Intensity (power) $TC_{(x,y)}$ is defined in Euclidean geometry as the square root of the sum of the squares of its coordinates:

$$R_{(x,y)} = \sqrt{(m_1 + m_2)^2 + (n_1 + n_2)^2} \quad (3)$$

If TC is created by transforming the expression $\frac{x}{y}$, then it follows:

$$TC_{(x,-y)} = \frac{x}{y} = \begin{bmatrix} L^m & 0 \\ 0 & T^m \end{bmatrix} \times \begin{bmatrix} L^m & 0 \\ 0 & T^n \end{bmatrix}^{-1} = \begin{bmatrix} L^{m_1-m_2} & 0 \\ 0 & T^{m_1-n_2} \end{bmatrix} \quad (4)$$

The determinant $D_{(x,-y)}$ of this matrix is represented by the expression:

$$D_{(x,-y)} = L^{m_1-m_2} \times T^{m_1-n_2} \quad (5)$$

Intensity (power) $TC_{(x,-y)}$ is defined in Euclidean geometry as the square root of the sum of the squares of its coordinates:

$$R_{(x,-y)} = \sqrt{(m_1 - m_2)^2 + (n_1 - n_2)^2} \quad (6)$$

PC $_{(x,x)}$ for the parameter x is calculated as follows:

$$PC_{(x,x)} = x \times x = x^2 = \begin{bmatrix} L^m & 0 \\ 0 & T^m \end{bmatrix}^2 = \begin{bmatrix} L^{2m} & 0 \\ 0 & T^{2m} \end{bmatrix} \quad (7)$$

The determinant $D_{(x,x)}$ of this matrix is represented as follows:

$$D_{(x,x)} = L^{2m_1} \times T^{2m_1} \quad (8)$$

Intensity (power) $PC_{(x,x)}$ is defined in Euclidean geometry as the square root of the sum of the squares of its coordinates:

$$R_{(x,x)} = \sqrt{(2m_1)^2 + (2n_1)^2} \quad (10)$$

Since TC contains PC, their power ratio can be calculated through the ratio of determinants:

$$D_{(x,x)} - D_{(x,y)} = x + x - (x + y) = D_{(x,-y)} = x - y \quad (10)$$

The expression $D_{(x,-y)}$ is calculated according to (5). The intensity of the relationship $TC_{(x,y)}$ and $PC_{(x,x)}$ is calculated according to (6).

By introducing the normalized value R_n intensity of the relationship $TC_{(x,y)}$ and $TC_{(x,y)}$ a more objective assessment of the state of forces existing in TC is obtained:

$$R_n = \frac{R_{(x,-y)}}{R_{(x,y)}} \quad (11)$$

A resource is an unknown substance, field (energy), time, space, information and function that can be used to transform an abstract idea for solving an inventive problem obtained in the form of a physical quantity $L^m T^n$ into a real solution, after defining TC and PC and calculating their intensity in an inventive problem. Available resources can be divided into 2 main groups [17-19]:

- 1) Spatial, temporal and external suffield (substances + field) resources
- 2) Informational and functional resources.

In (11) the conflicting relationship between two forces of contradiction that work in opposite directions can be seen. In one of them there is an attempt at improving the useful function of an ES. In that case there is a search for temporal, spatial and external suffield resources. In another case there is an attempt at eliminating the damaging function. That is why there is a search for the informational-functional resources.

Spatial resource is the total free space in the operational zone where there is an inventive problem, in other parts of the ES and in the ES as a whole. This term also includes cavities, distances between components, geometry of shapes, internal structures of ES components, etc. Time resources are time intervals before, during or after the considered conflict event, which can be used to prevent, neutralize or correct its negative consequences. External resources are made up of substances and fields (energy). This includes all substances in different states of matter, their combinations, as well as all technical and natural objects. Field resources or energy resources are forms of energy, physical fields, all forces and interactions between material objects. The physical properties of the first group of resources are obtained by multiplying the parameters x and y , and the product is represented in the form of the expression $L^m T^n$.

Identification and use of information resources in the ES and the supersystem should be realized through available information on the state and properties of substances, fields, spaces, on possible changes in the flow of information. To solve the inventive problem, all available functional resources in the system and its supersystem, as well as the environment, should be identified and used. The second group of resources is obtained by dividing the parameters x and y , i.e., by their transformation, and is presented in the form of the expression $L^m T^n$.

The calculated qualitative-quantitative physical characteristics identified in the LT - contradiction matrix as a result of multiplying or dividing two different parameters that make up TC or multiplying the same parameter with itself that makes the PC, are presented as X-element, which must be translated into a

real resource that exists in an ES or in its supersystem. By introducing a real resource in an ES, the inventive problem in an ES is solved. A detailed description of available real resources is given in the literature [17]. Calculating the ideality of ES, i.e. the obtained HDIS of the inventive problem is performed according to the procedure given in the literature [20-22].

3. CASE ANALYSIS

The filter protective suit (FPS) is intended for protection of people from highly toxic substances (HTS) (Figure 1). Four different domestic variants of the FPS were made, with the maximum ideality of one variant being achieved in the amount of 69.9% [22]. Such a FPS has the following properties:

- provides a time of protection against the mustard gas vapor of at least 6 h;
- protective power on the effect of HTS drops is at least 30 min;
- the outer layer does not absorb more than 40% of water;
- air permeability at a pressure difference of 100 Pa is up to do $40 \text{ m}^3/\text{m}^2\text{min}$;
- the suit retains its protective properties at temperatures from -30°C to $+50^\circ \text{C}$;
- the weight of the suit is a maximum of 3 kg;
- shelf life in storage conditions is at least 5 years, while in operating conditions without the presence of HTS it is at least 30 days;
- in case of contamination with the vapor phase of HTS, the suit can be reused only in exceptional cases, after air ventilation for at least 30 min. In case of HTS drop contamination, the suit is destroyed.



Figure 1. The FPS in protective position (left) and its components (right)

Since the outer and inner layers of the FPS are connected into one whole by sewing in the component places, their connection is called "sandwich material". The outer layer is made of woven textile materials based on cotton-polyester (50%). Its hydrophobicity and lipophobicity are achieved by fluorocarbon and silicone processing of textile material, and flame resistance by the installation of flame retardants such as poly-paraphenylene terephthalamide and the like.

The outer layer is made of treated fabric that protects against dripping HTS contamination. It prevents direct contact of the liquid part of the agent with the thin-layer carbon material. This thin carbon material protects against the effects of percutaneous HTS vapors. Their compound is a form that provides complete protection against HTS at a predefined time.

HTS drop protection can be achieved in two fundamentally different ways. The first is achieved by wetting, and the second by repelling drops that fall on the outer surface of the textile material. The increased wettability aims to spread the droplets to as wide an area as possible, thus increasing the evaporation flux towards the atmosphere. In that case, the concentration gradient of the liquid phase towards the body is much smaller. In the second principle, the drop remains with an approximately formed sphere, and the penetration takes place more slowly under the influence of external pressure and is concentrated on a smaller surface of the textile material. In both cases, only HTS vapor can reach the inner layer of the FPS.

HTS vapor molecules reach a thin boundary layer around the particles of active carbon material. Mass diffusion then takes place, with almost the entire mass being absorbed in the micropores of the spherical carbon material.

When the current of the air contaminated with HTS passes through the protective material, the kinetic processes take place first. Thin carbon materials limit absorption. Therefore, the rate of absorption of HTS vapor must be as high as possible, and the absorption zone of thin carbon materials as low as possible.

The decisive factor for the comfort of FPS is the permeability of water vapor. In the case of spherical carbon materials, the vapor permeability is good and the water vapor molecules in the spherical absorbers are poorly bound. Due to that, a slight desorption occurs and a normal pressure gradient is established relatively quickly as soon as the relative humidity on the outside of the FPS decreases. In addition, thin spherical carbon materials have good flexibility, which gives them good carrying properties.

If the purpose of a FPS is expanded so that it more effectively protects not only from HTS, but also from biological agents (BAG) including coronaviruses, at the same cost of production, then it is evident that this will achieve ideality above 70%.

The need for a FPS-CB construction to protect against chemical (C) and biological (B) agents is evident. Today, body protection isolates (different types of overalls) are most often used for protection against coronavirus. However, wearing them for a longer period of time can lead to physiological inadequacies, including the occurrence of heat stress, and thus endanger the life and health of the user. This reduces the comfort of the user of the insulating protective suit. When a FPS is used, then not only good protection from HTS is provided, but also good physiological suitability, i.e. comfort for the wearer of such a device. However, if FPS-CB is expected to protect the user from chemical and biological agents at the same time, it is obvious that this increased level of protection will affect the deterioration of physiological suitability, i.e., comfort. This situation leads to an inventive problem that requires an adequate solution.

4. RESULTS AND DISCUSSION

The main problem with the construction of FPS-CB is how to make a 2-layer FPS-CB from 2-layer FPS-C, since the

expansion (improvement) of protection from chemical and biological agents requires the introduction of a new protective layer that protects well against BAG, but causes an excessive increase in FPS-CB mass (Figure 2).

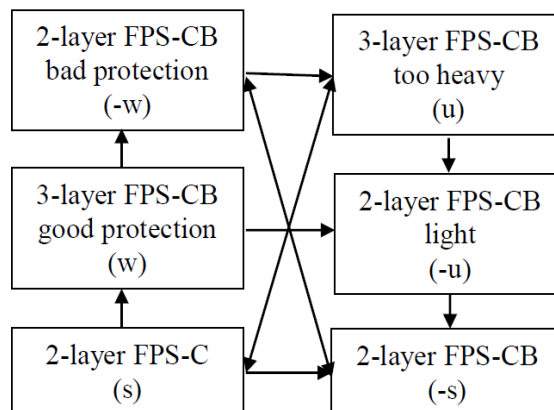

Figure 2. The Butterfly diagram for the FPS-CB problem

Legend: *w* is a wanted function of *s*; *u* is an unwanted function caused by satisfying a state *s*, which is a condition for supporting *w*; *-s* is a condition for supporting.

In order to construct FPS-CB, it is important to consider the interrelationships of the following parameters: permeability, mass loss of a stationary object, absorption rate, mass of a stationary object. Table 1 shows their relationship. By combining the above parameters, 12 TC and 4 PC can be selected (Table 1).

Table 1. Fragment of LT-contradiction matrix related to solving an inventive problem in FPS-CB construction (TC - technical contradiction, PC - physical contradiction)

CHARACTERISTICS								
		LT-value	Gene trend, Sn+m	22	29	31	42	
Improvement	22	Permeability	$L^{-2}T^1$	-1	PC	TC	TC	TC
	29	Loss of mass of a stationary object	L^3T^{-3}	0	TC	PC	TC	TC
	31	Speed	L^1T^{-1}	0	TC	TC	PC	TC
	42	Mass of a stationary object	L^3T^{-2}	1	TC	TC	TC	PC

TC created by crossing parameter no. 22 - Permeability (*x*) and parameter no. 29 - The mass loss of a stationary object (*y*) is shown by the following parameter expression:

$$x = \begin{bmatrix} L^{-2} & 0 \\ 0 & T^1 \end{bmatrix}, y = \begin{bmatrix} L^3 & 0 \\ 0 & T^{-3} \end{bmatrix}$$

TC shown as product xy is obtained using (1):

$$TC_{(x,y)} = xy = \begin{bmatrix} L^{-2} & 0 \\ 0 & T^1 \end{bmatrix} \times \begin{bmatrix} L^3 & 0 \\ 0 & T^{-3} \end{bmatrix} = \begin{bmatrix} L^1 & 0 \\ 0 & T^{-2} \end{bmatrix}$$

The determinant $D_{(x,y)}$ of this matrix is represented by (2) as follows:

$$D_{(x,y)} = L^1 \times T^{-2}$$

Intensity (power) $TC_{(x,y)}$ is calculated using (3):

$$R_{(x,y)} = \sqrt{(-1)^2 + (-2)^2} = \sqrt{5} = \pm 2.236$$

If TC is created by transforming the expression $\frac{x}{y}$,

then according to (4) it follows:

$$TC_{(x,-y)} = \frac{x}{y} = \begin{bmatrix} L^{-2} & 0 \\ 0 & T^1 \end{bmatrix} \times \begin{bmatrix} L^3 & 0 \\ 0 & T^{-3} \end{bmatrix}^{-1} = \begin{bmatrix} L^{-5} & 0 \\ 0 & T^4 \end{bmatrix}$$

The determinant $D_{(x,-y)}$ of this matrix is represented by (5):

$$D_{(x,-y)} = L^{-5} \times T^4$$

Intensity (power) $TC_{(x,-y)}$ is calculated using (7):

$$R_{(x,-y)} = \sqrt{(-5)^2 + (4)^2} = \sqrt{41} = \pm 6.403$$

PC_(x,x) for the parameter x is calculated as follows:

$$PC_{(x,x)} = x \times x = x^2 = \begin{bmatrix} L^{-2} & 0 \\ 0 & T^1 \end{bmatrix} = \begin{bmatrix} L^{-4} & 0 \\ 0 & T^1 \end{bmatrix}$$

The determinant $D_{(x,x)}$ of this matrix is determined using (8):

$$D_{(x,x)} = L^{-4} \times T^1$$

Intensity (power) PC_(x,x) is expressed using (9):

$$R_{(x,x)} = \sqrt{(-4)^2 + (1)^2} = \sqrt{17} = \pm 4.123$$

Since TC contains PC, their power ratio $D_{(x,x)} - D_{(x,y)}$ can be calculated through the ratio of determinants given in (5) and (10). The intensity of the relationship $TC_{(x,y)}$ and $PC_{(x,y)}$ given over the expression $R_{(x,-y)}$ was obtained by using the (11).

By introducing the standardized value R_n intensity of the relationship $TC_{(x,-y)}$ and $TC_{(x,y)}$ given in (11), an objective assessment of the state of forces existing in TC is obtained:

$$R_n = \frac{R_{(x,-y)}}{R_{(x,y)}} = \frac{6.403}{2.236} = 2.864$$

In a similar way, all other TC and PC from Table 1, whereby their values given in Table 2.

From Table 2 it can be seen that the highest intensity of contradiction R_n is in TC, which consists of

parameters no. 42 and 29 with value $R_n = 0.128$. This means that in the case of a reduction in the mass of a stationary object (FPS-CB) there is inevitably a loss of mass of a stationary object. Since FPS consists of an inner layer on which spherical activated carbon grains are impregnated, and an outer layer of woven material with an impregnated protective layer showing lipo-phobicity and hydrophobicity, this means that the thickness of the inner layer is reduced. This will weaken the protection of the FPS. The structure of the contradiction is such that the stronger intensity of the contradiction shows $TC_{(x,y)} = 7.81$ which was created by multiplying 2 selected parameters, than is the case with $TC_{(x,-y)} = 1$ which is created by dividing the two parameters.

Table 2. Aggregate representatn R_n , the strength of $TC_{(x,y)}$ and $TC_{(x,-y)}$ respectively, in the inventive problem of the FPS-CB construction

CHARACTERISTICS		Deterioration						
		LT-value	Gene trend, S_n+m	22	29	31	42	
Improvement	22	Permeability	$L^{-2}T^1$	-1	PC	2.92. 2 6.4	3.6 1 3.6	4.1 1.4 5.8
	29	Loss of mass of a stationary object	L^3T^{-3}	0	2.9 2.2 6.4	PC	0.5 5.6 2.8	0.1 7.8 1
	31	Speed	L^1T^{-1}	0	3.6 1 3.6	0.5 5.7 2.8	PC	0.5 5 2.2
	42	Mass of a stationary object	L^3T^2	1	4.1 1.4 5.8	0.1 7.8 1	0.5 5 2.2	PC

Multiplying the parameters 42x29 gives parameter no. 39 - Energy use of the moving object L^6T^{-5} . That moving object that weakens energy could be the Sun producing heat and electromagnetic radiation. That energy should be used in some way in FPS-CB. If we assume that FPS-CB should have two layers (inner and outer), then the inner should remain unchanged, i.e. it should retain a layer of spherical activated carbon that will absorb the HTS that penetrate it in the form of vapor. The sun's rays cannot reach the inner layer of the FPS. The outer layer of FPS-CB should be made of a woven material on which a thin layer of TiO_2 (alternatively: Zn, Cu or Ag) has been applied. In contact with sunlight, chemical and biological agents that reach the surface of FPS-CB are decontaminated. In this way, this outer layer becomes not only a physical, mechanical barrier to the passage of HTS and BAG droplets, but also a reactive layer that reacts with them. The external resource is the Sun, which enables that outer layer to become active protection instead of passive protection. In the paper [23-25] it was found that the protection of FPS from HTS is not only possible with TiO_2 , but it is necessary to combine activated carbon.

If we analyze the parameters that make up the second most important pair of technical contradictions 42 (mass of a stationary object) and 31 (velocity) of absorption whose value is $R_n = 0.447$, then in this

conflict the contribution of $TC_{(x,y)} = 2.828$ and $TC_{(x,y)} = 2.236$ is equal. In the first case, the TC solution is the size L^4T^{-3} (mass of the mobile object), and in the second L^2T^{-1} (acceleration). Acceleration of the reaction of HTS and BAG that reach the outer surface of FPS-CB can occur if that surface is transformed from passive, mechanical protection into a reactive substrate, such as for example the one that was impregnated with a thin layer of TiO_2 . Thus, this second consideration leads to the same construction of FPS-CB.

One way to modify textile materials so that they have self-decontaminating properties is to use metal oxide nanoparticles with photocatalytic properties. This can be achieved in two fundamentally different ways. One way is the de novo synthesis of nanofibers by the electrospinning process [26]. Conventional textile fibers have a diameter of 1-100 μm , while the electrospinning process produces fibers with a diameter of nanometer dimensions. Tests show that by inserting reactive nanoparticles of alumina, titanium oxide and magnesium oxide, fine fiber networks with decontaminating properties can be obtained, due to the photocatalytic action of these oxides that decompose HTS. Another way of using nanotechnology refers to the ways of finishing textile substrates. Thus, the textile surface can be modified by applying nano-tubes of metal oxides of tungsten and titanium to the fabric surface by the layer-by-layer method. It has been determined that such materials have excellent self-decontaminating properties. Also, it has been proven that cotton fibers can be coated with 20 sequential nanolayers of polystyrene sulfonate and poly (allylamine hydrochloride). The thickness and composition of each layer controls the transport of HTS through the modified textile, without compromising the comfort and mechanical properties of the material. The materials thus obtained can be applied to FPS-CB.

Titanium dioxide nanoparticles have been shown to be best for this purpose, due to their relatively simple synthesis, low cost, and low toxicity. There are numerous studies proving that TiO_2 micro- or nano-particles are not photo mutagenic or photo genotoxic to humans and there is no difference in their distribution and elimination from the body [27].

5. CONCLUSION

The LT-contradiction matrix is a reliable tool of inventology which is used for the mathematical-physical modeling of the process of finding a higher degree of ideality solution (HDIS) of inventive problems. Its use facilitates the acquisition of HDIS in inventive problems by reducing the influence of subjectivity in the decision-making process.

Multiplying two different physical parameters (xy) in the LT-contradiction matrix creates technical contradictions (TC). The formation of TC can also occur by dividing two different physical parameters (xy^{-1}). The numerical value of the product, i.e., the quotient, shows the intensity, i.e., the power of the TC in the inventive problem. The higher this numerical value, the stronger the power of the TC, and also the more significant its influence on the occurrence of the inventive problem. Within TC, there are physical contradictions (PC), the

solution of which achieves the HDIS of the inventive problem. It is created by multiplying one physical parameter (x) in the LT-matrix of self-contradiction, whereby the higher numerical value of the product is proportional to the strength of PC.

Regardless of the type of resource, the mathematical-physical resource obtained at a later stage must be identified as a real resource that exists in the engineering system (ES) or in its supersystem. By introducing it into the real ES, the HDIS of the inventive problem in an ES is achieved.

By calculating and comparing the normalized values of R_n of all conflicting pairs in the inventive problem, it can be determined which pair of physical parameters has the strongest influence of contradiction on its occurrence. The smaller the value of R_n , the stronger the conflict present in the inventive problem. However, by resolving that conflict there is a great chance to achieve the HDIS of the inventive problem.

The practical application of the LT-contradiction matrix is shown on the example of finding the HDIS of the inventive problem that arises during the development of FPS-CB. Similarly, this inventology tool can be used to find the HDIS for inventive problems in other ESs. Thus, this new inventology tool can be used, individually or combined with other TRIZ tools, to effectively find a solution to a problem with a higher degree of ideality.

ACKNOWLEDGMENT

This work was supported by the Ministry of Education, Science and Technological Development of the Republic of Serbia (Contract No. 451-03-68/2020-14/200135).

REFERENCES

- [1] Rajic, D.: LT – Contradiction Matrix, FME Transactions, Vol. 49, No. 1, pp. 95-102, 2021.
- [2] Rajic, S. D.: Inventive Level as a Basic for the Assessment of Scientific Contribution of Inventors, FME Transactions, Vol. 47, No. 1, pp.76-82, 2019.
- [3] Rajic, D.: Compatibility between TRIZ - contradiction matrix and LT-unit system, FME Transactions, Vol. 48, No. 2, pp. 460-467, 2020.
- [4] Bartini, R.: Some Relationships Between Physical Quantities. Dokl. Akad. Nauk SSSR, Ser. Fiz. 163, 4, pp. 861-864, 1965. (in Russian: Бартини, Р.: Некоторые соотношения между физическими константами./ Доклады Академии наук СССР. Том 163, No 4, С 861-864, 1965).
- [5] Bartini, R. O. and Kuznetsov, P. G.: On the Multiplicity of Geometries and the Multiplicities of Physical Sciences, Problems and Features of Modern Scientific Methodology, pp. 55–65, 1978.
- [6] Chujev, A. S.: Physical picture of the world in the dimension "length-time". *Series Informa-tization of Russia on the threshold of the XXI century.* - M., SINTEG, 1999 (In Russian: Чуев, А. С.: Физическая картина мира в размерности "длина-время", М., СИНТЕГ, 1999 г.), [Online] Available at [http://www.chuev.narod.ru/\(05.01.2021\)](http://www.chuev.narod.ru/(05.01.2021)).

- [7] Chujev, A. S.: On existing and theoretically possible force laws found in a system of physical quantities, 2003. (In Russian: Чуев, А. С.: О необходимости раздельного представления систем механических (гравитационных) и электромагнитных физических величин, 2003). [Online] Available at <http://www.sciteclibrary.ru/rus/catalog/pages/5811.html> / (05.01.2021).
- [8] Chujev, A. S.: About a multilevel system of physical quantities expressing the laws of nature, in particular, the structure and relationships of electromagnetic quantities, 2004. (In Russian: Чуев, А. С.: О многоуровневой системе физических величин, выражающей законы природы, в частности, структуру и взаимосвязи электромагнитных величин, 2004). [Online] Available at <http://www.sciteclibrary.ru/rus/catalog/pages/7335.html> / (05.01.2021).
- [9] Bushuev, A. B.: Search for quantitative estimates of resources in the Bartini basis / *Collection of reports of the VII international conference "TRIZ: application practice and development problems"*, 2015, Moscow, pp. 221-225. (In Russian: Бушуев А.Б.: Поиск количественных оценок ресурсов в базисе Бартини. *Сборник докладов международной конференции "ТРИЗ: практика применения и проблемы развития"* (Москва, 20-21 ноября 2015г.). С. 221-225.).
- [10] Bushuev, A.: General Problems of Metrology and Measurement Technique. Numerical Estimation of the Energy Information Circuits of Measurement Devices, *Measurement Techniques*, Vol. 60, No. 9, pp. 857-862, 2017.
- [11] Bushuev, A. B. and Petrov, V. A.: Simulation modeling of control systems in the LT basis, *Proceedings of the Eighth All-Russian Scientific and Practical Conference on Simulation Modeling and its Application in Science and Industry "IMMOD-2017" section 1.*, October 18-20.10.2017, St. Petersburg, pp. 88-93. (In Russian: Бушуев А.Б., Петров В.А.: Имитационное моделирование систем управления в LT-базисе. *Труды Восьмой Всероссийской научно-практической конференции "Имитационное моделирование. Теория и практика" (ИММОД-2017)* (СПб, 18-20 октября 2017г.). 2017. С. 88-93).
- [12] Bolshakov, B. E. and Petrov, A. E.: Algorithm of Multi-dimensional Space and Time Values Interrelation in the System of LT Dimension Coordinates by B. Brown, R. O. Bartini, P. G. Kuznetsov, *Journal of Engineering and Applied Sciences*, Vol. 12, Special Issues 3, pp. 6620-6627, 2017.
- [13] Rajic, D.: Innovative synergism as a result of TRIZ and LT-system synthesis, In book: *Innovation as an Initiator of the Development "Innovations - Development Prospects"*, *International Thematic Monograph - Thematic Proceedings*, Publisher: University Business Academy in Novi Sad, Faculty of Applied Management, Economy and Finance, Belgrade, 05.12.2019, pp. 226-242.
- [14] Rajic, D.: Contribution of eco-inventology to concept of sustainable development, In book: *Innovation as an Initiator of the Development "Innovations - Development Prospects"*, *International Thematic Monograph - Thematic Proceedings*, Publisher: University Business Academy in Novi Sad, Faculty of Applied Management, Economy and Finance, Belgrade, 05.12.2019, pp. 259-276.
- [15] Rajic, D.: Application of LT-Contradiction Matrix in Development of Weapons and Military Equipment, *9th International Scientific Conference on Defensive Technologies, OTEH 2020*, Belgrade, Serbia, 8-9 October 2020.
- [16] Rajic, D.: Application of LT-Contradiction Matrix in Innovation Development, In book: *Innovation as an Initiator of the Development "Innovations - Development Prospects"*, *International Thematic Monograph - Thematic Proceedings*, Publisher: University Business Academy in Novi Sad, Faculty of Applied Management, Economy and Finance, Belgrade, 03.12.2020, pp. 329-346.
- [17] Rajic, D.: *Inventology*, Author's edition, Belgrade, 2017. (In Serbian: Rajić, D.: *Inventologija*, Autorsko izdanje, Beograd, 2017).
- [18] Rajic, D.: *Eco-inventology*, Author's edition, Belgrade, 2019. (In Serbian: Rajić, D.: *Eko-inventologija*, Autorsko izdanje, Beograd, 2019).
- [19] Rajic, D.: *Creative Ecology*, Author's edition, Belgrade, 2016. (In Serbian: Rajić, D.: *Kreativna ekologija*, Autorsko izdanje, Beograd, 2016).
- [20] Rajic, D., Ivankovic, N. and Karkalic, R.: Defining the Ideality of the Protective Masks by the Mathematical Modeling Method, *FME Transactions*, Vol. 47, No. 3, pp. 496-501, 2019.
- [21] Rajic, D. and Ivankovic, N.: Contributions of Impregnated Silver Nanoparticles to Ideality Increase of Filtration Material in Human Respiratory Protection, *Material Protection*, Vol. 60, No. 4, pp. 360-368, 2019.
- [22] Rajic, D., Karkalic, R., Ivankovic, N., Otrisal, P. and Florus, S.: Defining Filtering Protective Suit Ideality Using a Mathematical-Modeling Method, *AATCC Journal of Research*, Vol. 6, No. 6, pp. 18-24, 2019.
- [23] Bauk, S., Vitorovic-Todorovic, M., Mazanec, K., Senic, Z., Pajic, N., Rajic, D.: Decomposition of organic dyes and CWA simulants by nano TiO₂ treated standard military textiles, *Proceedings of the 5th International Conference on Defensive Technologies*, Belgrade, 18-19.09. 2012, pp. 693-697.
- [24] Senic, Z., Bauk, S., Simic, D., Vitorovic-Todorovic, M., Markovic, T., Radojkovic, A. and Rajic, D.: The Preliminary Comparative Analysis of Different Routes for TiO₂ Nanoparticles Synthesis and Their Deposition on Textiles. The Methyl-Orange Degradation and VX Detoxication Study.

Digest Journal of Nanomaterials and Biostructures, No. 8, pp. 711-719, 2013.

- [25] Senic, Z., Bauk, S., Vitorovic-Todorovic, M., Pajic, N., Samolov, A. and Rajic, D.: Application of TiO₂
- [26] Nanoparticles for Obtaining Self - Decontaminating Smart Textiles, Scientific Technical Review, Vol. 61, No. 3-4, pp. 63-72, 2011.
- [27] Li, D. and Xia, Y.: Electrospinning of Nanofiber: Reinventing the Wheel?, Adv. Mater., No. 16, pp. 1151-1170, 2004.
- [28] Schilling, K., Bradford, B., Castelli, C., Dofour, E., Nash, J. F., Pape, W., Schule, S., Tooley, I., Van den Bosch, J. and Schelauf, F.: Human Safety Review of Nano Titanium Dioxide and Zink Oxide, Photochem. Photobiol. Sci., No. 9, pp. 495-509, 2010.

МАТЕМАТИЧКО - ФИЗИЧКИ МОДЕЛ РЕШАВАЊА ИНВЕНТИВНИХ ПРОБЛЕМА

Д. Рајић

Просторно - временска ЛТ - матрица контрадикторности је алатка инвентологије која путем математичко-физичког моделовања омогућује егзактне прорачуне одређених параметара у инжењеринг систему. Помоћу ње се објективизује процес одлучивања и стварају предуслови да се са већом вероватноћом дође до адекватног ресурса (X-елемента), а тиме и до већег степена идеалности коначног решења инвентивног проблема. Помоћу ЛТ-матрице контрадикторности се може описати било који инжењеринг систем који генерише инвентивни проблем. Укрштањем одговарајућих параметара у ЛТ-матрици контрадикторности, уз помоћ диференцијалне геометрије тензора, може се извршити квалитативно-квантитативна анализа и прорачун релевантног степена идеалности свих контрадикција које постоје у инвентивном проблему. Након тога је олакшан пут до проналажења физичке карактеристике X-елемента у математичко-физичком моделу, односно налажење реалног ресурса који ће омогућити већи степен идеалности коначног решења инвентивног проблема у инжењеринг систему.